

DELTA GEL are sealed maintenance-free lead-acid batteries with gas recombination system (VRLA). Batteries are manufactured using AGM + GEL technology and are equipped with a built-in LCD display showing the battery status: voltage, charge level and operating time. The information panel is activated by pressing the button. In the case of low voltage, an alarm is triggered. The batteries are designed for standby and cycle uses. Recommended for use in autonomous power systems, and also in conjunction with systems based on renewable.



**Battery construction**

Element	Positive plate	Negative plate	Case	Lid	Valve	Terminal	Separator	Electrolyte
Material	Lead dioxide	Lead	ABS		Rubber	Copper	Fiberglass	Acid

**Specifications**

Nominal voltage.....12 V  
 Cell.....6  
 Design life.....10-12 years  
 Nominal capacity (25°C)  
     10 hours rate (20 A; 1,8 V/cell).....200 Ah  
     5 hours rate (35,3 A; 1,75 V/cell).....176,5 Ah  
     1 hours rate (124 A; 1,65 V/cell).....124 Ah  
 Self-discharge.....3% capacity per month 20°C  
 Internal resistance (25°C).....2,5 mΩ

**Operating temperature range**

Discharge.....-20÷60°C  
 Charge.....-10÷60°C  
 Storage.....-20÷60°C  
 Maximum discharge current (25°C).....1000A (5sec)  
 Cycle mode (2,35÷2,4 V/cell)  
     Max.charge current.....40 A  
     Temperature correction factor.....30 mV/°C  
 Standby mode (2,25÷2,3 V/cell)  
     Temperature correction factor.....20 mV/°C

**Application**

- Uninterruptable power supply
- Communication system
- Renewable energy systems
- Autonomous power supply systems
- Medical equipment, wheelchairs

**Performance & characteristics**

- Combined AGM + GEL technology  
Long service life;
- Deep discharge stability;
- Temperature stability characteristics;
- Excluded acid leaks, guaranteed safe operation with other equipment;
- There is no gas evolution, enough natural ventilation;
- Maintenance-free. Do not require distillate topping;
- The battery case is made of flame retardant ABS plastic.

**Dimensions (±2mm)**

Length, mm.....522  
 Width, mm.....239  
 Height, mm.....217  
 Height over terminals, mm.....222  
 Weight (±3%), kg.....64,7

**Layout**  
F



**Terminal type**  
Insert Ø8 mm

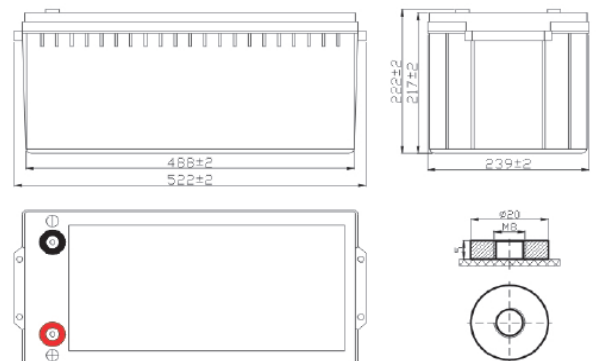
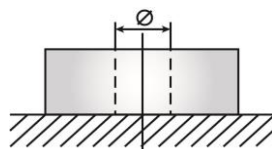

**Discharge Constant Current, A ( 25°C)**

V/cell	15 min	30 min	45 min	1 h	3 h	4 h	5 h	8 h	10 h
1,60	326	219	159	128	53,0	44,7	39,6	25,1	20,2
1,65	311	210	153	124	51,1	43,2	38,1	24,6	20,2
1,70	296	202	147	120	49,3	41,7	36,8	24,2	20,1
1,75	281	191	140	114	47,9	40,1	35,3	23,7	20,1
1,80	265	181	132	108	45,3	38,1	33,6	23,2	20,0

**Discharge Constant Power, W/cell ( 25°C)**

V/cell	15 min	30 min	45 min	1 h	3 h	4 h	5 h	8 h	10 h
1,60	565	390	287	234	96,7	81,0	69,7	45,9	37,4
1,65	549	381	281	230	95,6	79,1	67,0	45,4	37,0
1,70	531	371	275	226	94,2	78,0	66,3	44,9	36,7
1,75	513	358	266	218	92,0	77,3	66,0	44,5	36,4
1,80	490	343	255	211	90,0	76,4	65,0	44,3	36,2

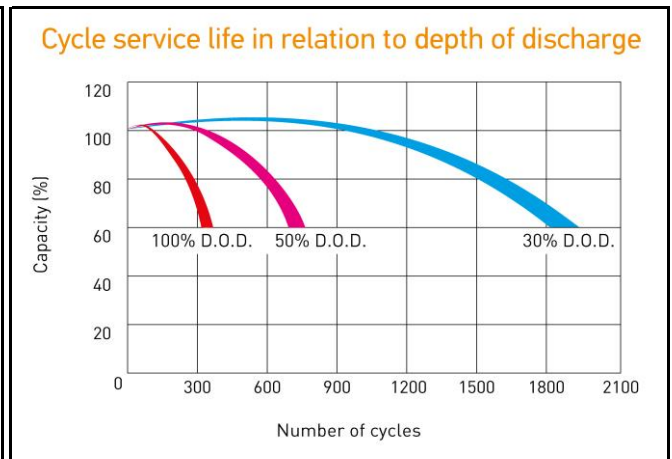
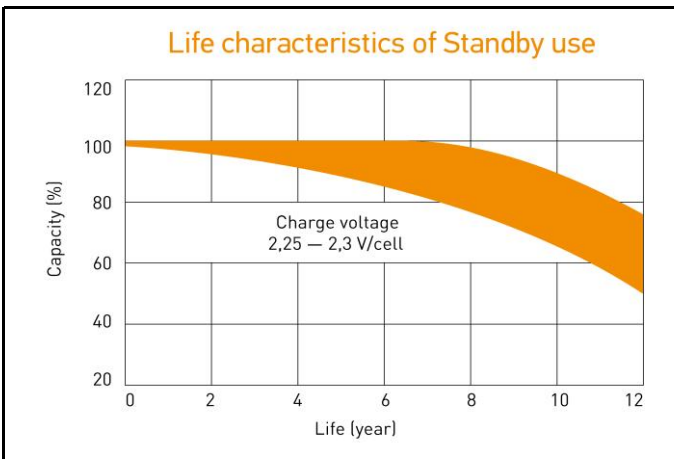
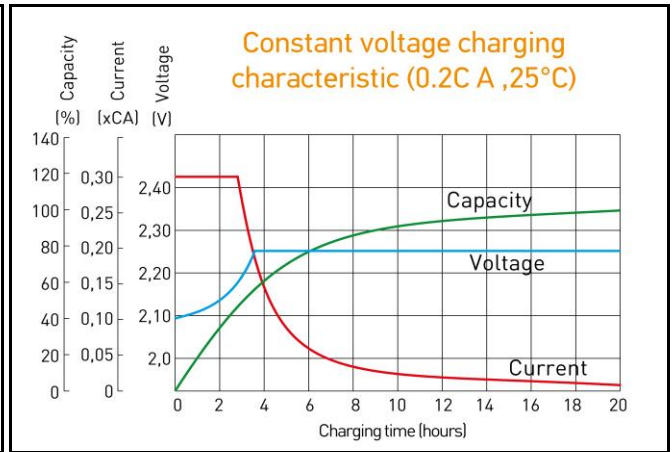
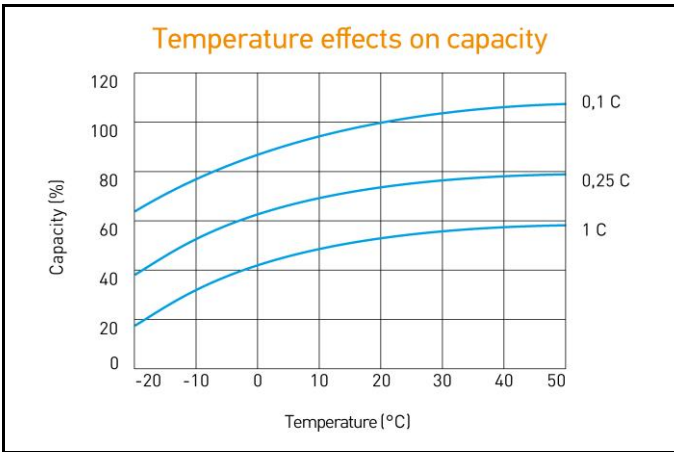

ALL DATA IS SUBJECT TO CHANGE WITHOUT NOTICE