

12.8V 200Ah

Provides Safe and Efficient LFP Battery Solutions.

designed for different types of applications, such as small UPS, energy storage, portable mobile powersupply, which is the best choice of small capacity, long standby or cycle use.



Features

- . Safest lithium battery technology
- . Lithium iron Phosphate Battery(LiFePO₄)
- . Eco-friendly
- . Special protection plate, supporting parallel
- . Multiple safety protection
- . Intelligent balancing function

Mechanical Specifications

Case Material	ABS
Cell Type-Chemistry	Prismatic LiFePO ₄
Terminal Type	M8
IP Grade	IP65

BMS Characteristics

Recommended Charge Current	50A
Maximum Charge Current	100A
Maximum Continuous Discharge Current	200A
Recommended Charge Voltage	13.6~13.8V
Max Charge Voltage	14.6V
Overcharge Protection Voltage	14.8~15.2V
Charge Mode	CC/CV
Discharge Cut-off Voltage Range	11.2V

Basic Performance

Nominal Voltage	12.8V
Nominal Capacity	200Ah
Standard Discharge Time	200A @60min
Energy	2.56KWh
IR	<= 10mΩ
Self Discharge	<=2%/Month
Cells	Square 100Ah
Cycle Life	4000 times(1C/1C)
Size	522*238*223
Weight	19.5

Compliance

Certifications	CE/UN38.3/UL1642/IEC62133
Transport Appraisal	UN3480,CLASS 9

Charge Performance

Rated Charge Current	50A
Maximum Charge Current	100A
Rated Charge Voltage	13.6~13.8V
Charge Cut-off Voltage	> 14.8V(0.5~1.5S)
Reconnect Voltage	<14.4 V
Balancing Voltage	<14V
System Series	<=6

Discharge Performance

Rated Discharge Current	200A
Pulse Current(<=5S)	1000A
Rated Discharge Cut-off Voltage	11.2V
Minimum Discharge Cut-off Voltage	>10V
Reconnect Voltage	>10.4V
Short Circuit Protection	200~600 μs
Short Circuit Current	Approx. 2000A

Temperature Performance

Discharge Temperature	-20~60°C
Charge Temperature	0~45°C
Storage Temperature	-5~35°C
High Temperature Cut-off	65°C
Reconnect Temperature	48°C

Size

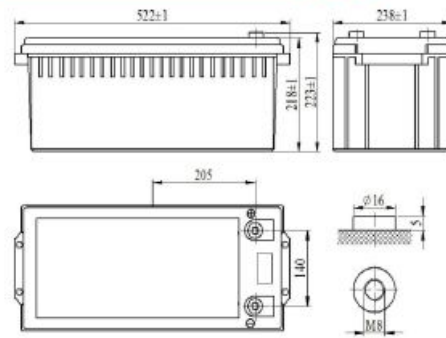

Characteristics Curve

Discharge Performance at 25°C

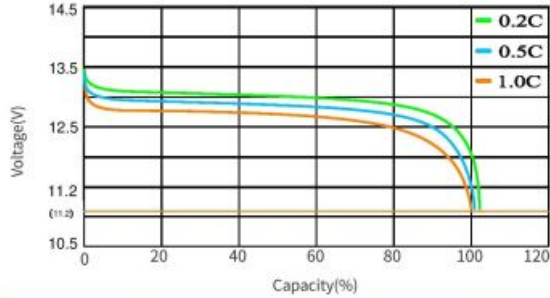

Charge and Discharge at 25°C, 0.5C

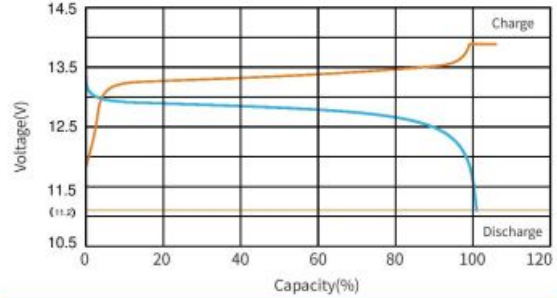

Temperature Effects on Capacity at 0.5C

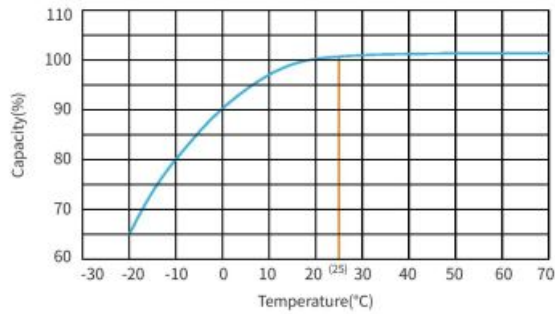

Cycle Life with DOD at 25 °C
1C Discharge and 1C Charge

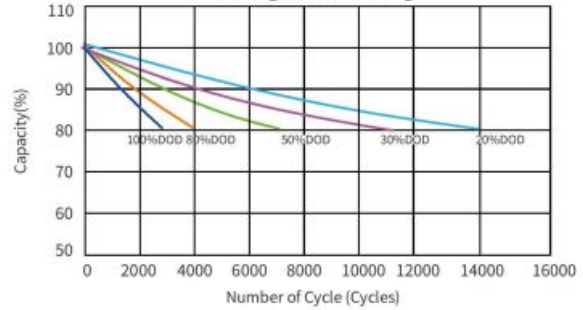

Cautions

1. Do NOT short circuit, crush or disassemble.
2. Do NOT heat or incinerate.
3. Do NOT immerse in any liquid.
4. Store at 50% capacity. Recharge every 3 months. The storage area should be clean, cool, dry and ventilated.
5. Disconnect charging source prior to connecting or disconnecting battery terminals.
6. Do not dispose of batteries in a fire as they can explode.
7. Do not open, alter, or mutilate batteries. Released electrolyte is harmful to skin and eyes. It may be toxic.
8. Do not mix different types and brands of lithium-ion batteries.
9. Do not dispose in trash, follow local regulations and manufacturer's instruction.
10. See installation instructions before connecting to the supply.
11. The battery cabinet receives power from more than one source. Disconnection of all DC sources is required to De-energize this unit before installing or servicing.
Wait 5 minutes before opening the unit.
12. Do not install on or over combustible surfaces.
13. Refer to manual before servicing.
14. Do not touch bare terminals.