

S Series User Manual

1、 Introduction

S 12V series designed for different types of applications, such as small UPS, home energy storage, portable mobile power supply and Recreational Vehicle, which is the best choice of small capacity, long time standby or cyclic use.

BMS is built into the battery system, which is responsible for collecting and analyzing the voltage, temperature and current of the single cell. It has the functions of over-voltage protection, under-voltage protection, high temperature protection, low temperature protection, short circuit protection and cell balance.

2、 Overview

Model	S12-100+LCD	S12-100B+LCD	S12-200+LCD	S12-200B+LCD	S12-300+LCD
Nominal Voltage	12.8V				
Capacity	100Ah	100Ah	200Ah	200Ah	300Ah
Cell	3.2V-100Ah	3.2V-100Ah	3.2V-100Ah	3.2V-100Ah	3.2V-100Ah
Cells Grouping	4S1P	4S1P	4S2P	4S2P	4S3P

3. Dimension :

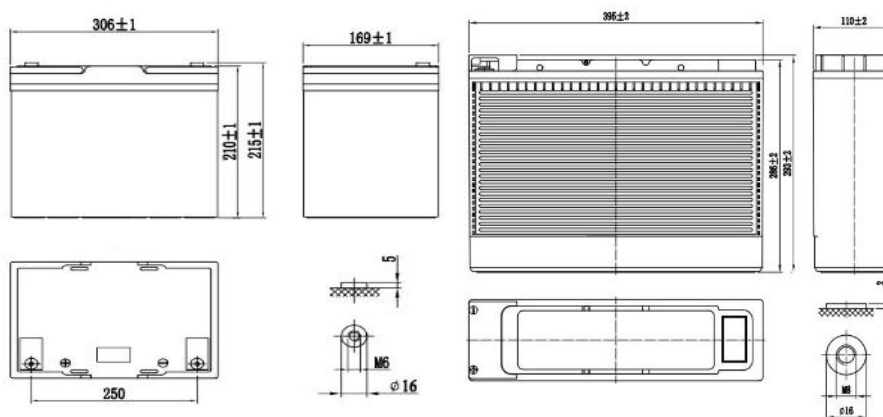

S12-100+LCD

S12-100B+LCD

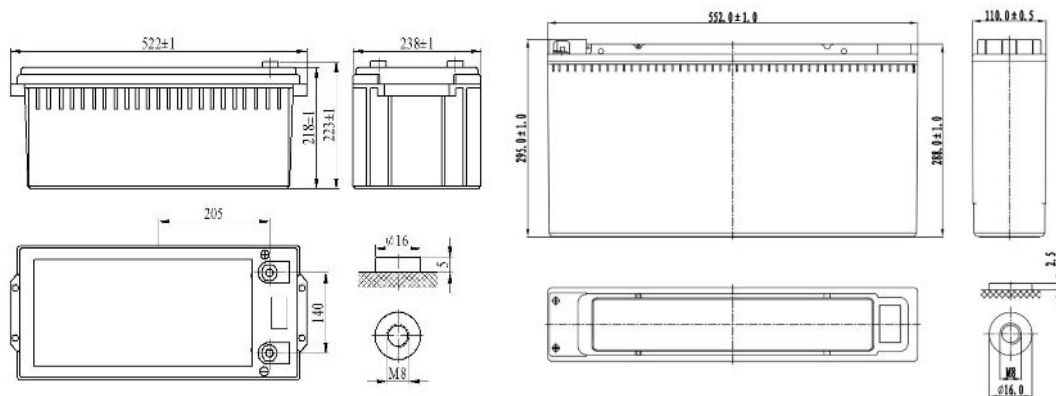

S12-200+LCD

S12-200B+LCD

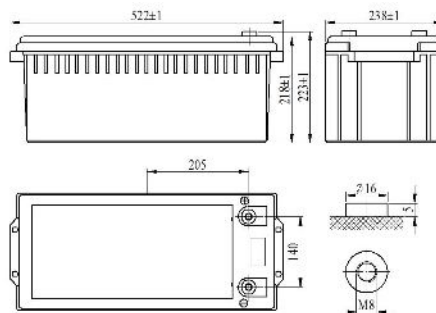

S12-300+LCD

4. Parameter

Model	S12-100+LCD	S12-100B+LCD	S12-200+LCD	S12-200B+LCD	S12-300+LCD
Rated Voltage(V)	12.8V				
Rated Capacity(Ah)	100Ah	100Ah	200Ah	200Ah	300Ah
Rated Energy(KWh)	1.28KWh	1.28KWh	2.56KWh	2.56KWh	3.84KWh
Maximum Charging Current(A)	100A	100A	100A	100A	100A
Maximum Discharging Current(A)	100A	100A	200A	100A	200A
Discharge Cut-off Voltage(V)	11.2V				
Charging	13.6 ~ 14.4V				

Voltage					
Life Cycle (@25°C , 0.5C/0.25C, 80%DOD)	Approx .2800 Cycles				
Total Weight(Kg)	9.8Kg	10.4kg	19.5kg	19.0kg	27.4kg
Internal Resistance Fully Charged@ 25°C	≤10m Ω	≤ 10m Ω	≤ 5m Ω	≤5m Ω	≤4m Ω
Thermal Management	Nature cooling				
Operating Humidity	60±25%R.H.				
Operating Temperature	Charging 0 ~ 50°C				
	Discharging -25°C ~65°C				

5、 Performance

- High acquisition of voltage data collection (5mv).
- Customized BMS function and parameter.
- Intelligent equalization management.
- Over Charging, Over Discharging, Over Temperature, Short Circuit Protection
- This BMS supports a matrix of 6 battery in series X 6 battery in parallel. A total of 36 batteries in the matrix.

6、 Installation Guide

6.1 Preparation

Before installation, please read all safety information provided in this document. If you have any questions about operation and safe use of the battery system, please contact the technical support engineer immediately for a free consultation.

Before Operation:

- Qualified electric worker qualification is mandatory.
- Remove all metal items, such as jewelry, watch, pen etc.

-
- To ensure the safety of construction personnel and equipment, disconnect the battery pack from the operating equipment during wiring.
 - Pay attention to the terminal voltage polarity of the battery module.
 - Make sure installation tools insulating and use tools correctly.
 - Follow the connection port description and system connection diagram.
 - It is absolutely forbidden to plug and unplug when the battery is working. Necessary operation should be done after the power supply is disconnected.
 - Before the formal operation, ensure whether the power terminals are properly connected and tighten the terminals; When it is necessary to measure, be careful to use instruments and tools, to avoid short circuit and other accidents.
 - It is strictly prohibited to disassemble the battery without permission of the professional technician from manufacture.

6.2 Installation Tools

Torque Wrench	
Cross Screwdriver	
Insulating Gloves	
Multimeter	

6.3 Appearance

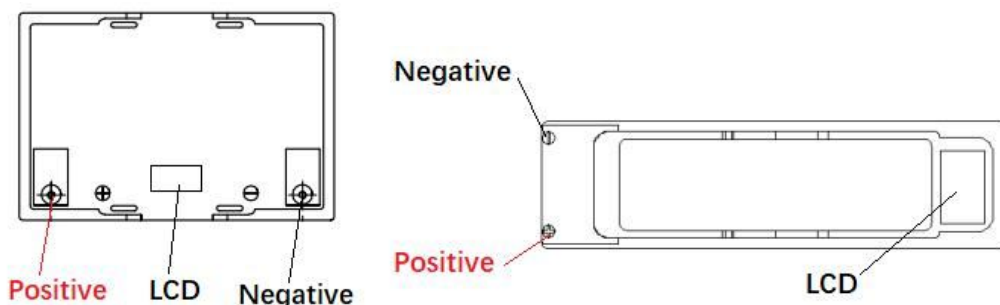

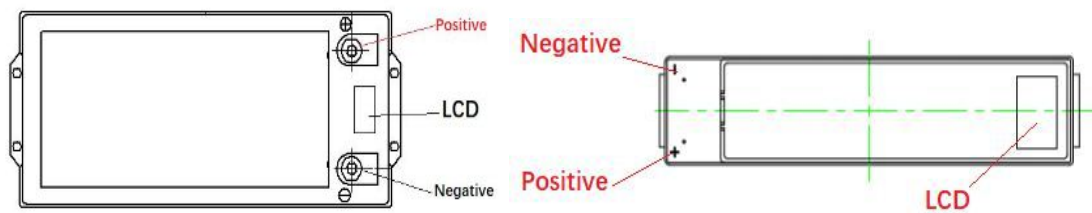

6.4 Battery Connection

To connect in series or /and in parallel, batteries should meet below conditions:

- the same battery capacity (Ah).
- from same brand (as lithium battery from different brands has their special BMS).
- purchased in near time (within one month).

6.4.1 Two Necessary Steps Before Connecting

These two steps are necessary in order to reduce the voltage difference between batteries, and through these, the battery system can perform the best of it in series and in parallel.

Firstly, fully charge your 6 batteries separately. Secondly, leave them together for 12-24hrs, connect your six batteries one by one in series. And then, you can connect your batteries in parallel. This battery BMS supports a matrix of 6 battery in series X 6 battery in parallel. A total of 36 batteries in the matrix.

6.4.2 Battery Series :

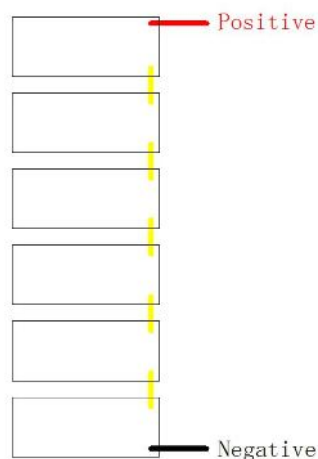

6.4.3 Battery Parallel :

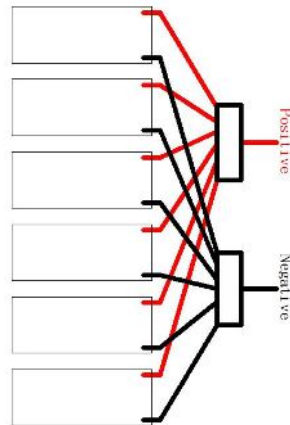

6.4.4 Battery Series and Parallel (Max 6S6P) :

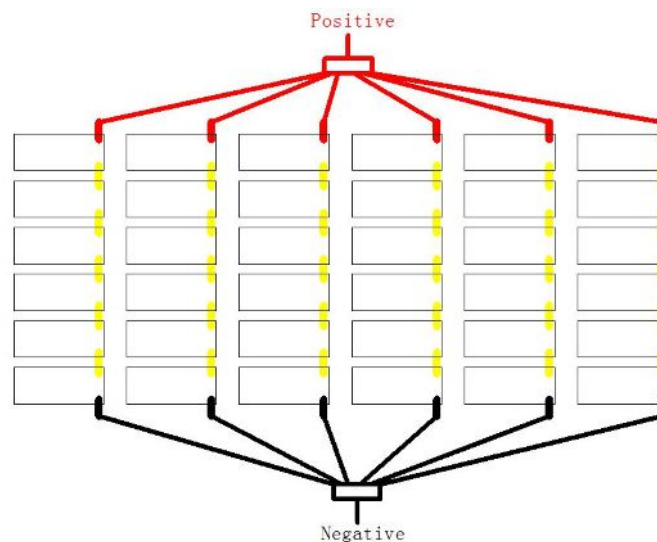

7、 Attention

- Charging current shall be less than the maximum charging current specified in the data sheet. Charging current exceeding the recommended current may damage the battery.
- The discharge current shall be less than the maximum discharge current specified in the product specifications; Discharge current bigger than the recommended current may damage the battery.
- Non-professional personnel is not allowed to disassemble the battery.
- Reverse charging the battery is strictly prohibited.
- Battery pack should not be used or placed at high temperature. It will cause overheat,

function failure or shorter life.

- Battery pack should be placed in dry and cool environment when it is not in use. Immersing into water is prohibited.
- It is strictly prohibited to install and disassemble the battery pack when it is live.
- For optimum performance, you must charge at 14.6V. If you do not, you will not be able to reach the full usable capacity of the battery.
- To ensure the best performance of the battery when stored for a long time, the battery should be charged and discharged every three months.
- After the battery discharge protection, it can be removed by the following ways:
 1. Let the battery stand for 15-20 min
The battery will be automatically unprotected after standing for 15-20 min.
 2. Use the charger with OV charging function
(It can charge the battery starting from 0V) to charge the battery. After fully charged, the battery can be used normally.
 3. Use another 12V lithium battery with same capacity to connect in parallel with the battery and put them aside for over 12hrs. After that, fully charge the battery and it can be used normally.
- If solar charging is used, please set the regulator to the charging mode of B04 lithium battery.

When charged with controller, and the controller output is used to connect load:

It is recommended that the controller is set as below parameters to avoid the battery fail to recover when the BMS cut off the battery for protection after a continuous small current discharge.

Overcharge Protection Voltage : 14.6V

Overcharge Recovery Voltage: 14.2V

Over-discharge Protection Voltage: 11.2V

Over-discharge Recovery Voltage: 11.6V

The above settings can ensure that the controller triggers the protection first instead of the battery BMS, which can prolong the service life of the battery.

8、 LCD Usage Procedure

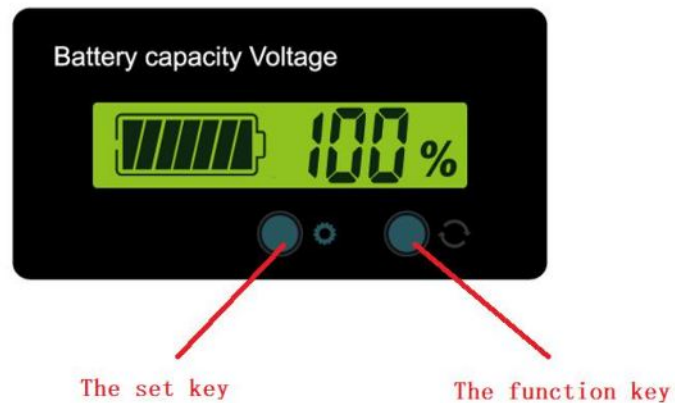

1. When the display is off, press the function key, the display will light up and display the battery voltage.
2. Press the function button again to display the battery SOC.
3. Press the function button again, the display screen is off.

9、 Product model comparison table

TCSN battery model	VOLTX battery model	Voltage	Capacity
S12-100+LCD	LI-T12V-G-PMS-A0-X-LCD	12.8V	100AH
S12-100B+LCD	LI-T12V-SLIM-PMS-A0-X-LCD	12.8V	100AH
S12-200+LCD	LI-T12V-G-PMS-B0-X-LCD	12.8V	200AH
S12-200B+LCD	LI-T12V-SLIM-PMS-B0-X-LCD	12.8V	200AH
S12-300+LCD	LI-T12V-G-PMS-C0-X-LCD	12.8V	300AH