

User Manual

8KW SOLAR INVERTER / CHARGER

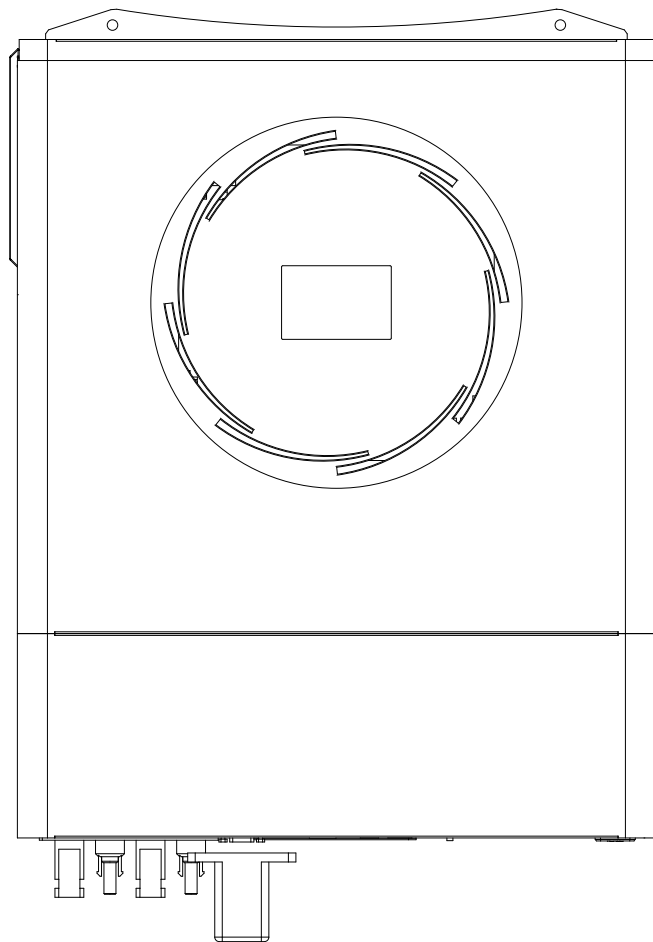

Table Of Contents

1. About This	1
1.1 Manual Purpose.....	1
1.2 Scope	1
2. Safety Instructions	1
3. Introduction.....	1
3.1 Features	1
3.2 Basic System Architecture	2
3.3 Product Overview.....	3
4. Installation	4
4.1 Unpacking And Inspection	4
4.2 Preparation	4
4.3 Mounting The Unit.....	4
4.4 Battery Connection	5
4.5 AC Input/output Connection	7
4.6 PV Connection	8
4.7 Final Assembly	12
4.8 RS232/USB Communication Connection.....	12
4.9 Wi-Fi Connection (Optional)	12
4.10 Dry Contact Signal	13
5. Operation.....	14
5.1 Power ON/OFF	14
5.2 Operation And Display Panel	14
5.3 LCD Display Icons	15
5.4 LCD Setting	16
6. Parallel Installation Guide.....	23
6.1 Parallel Operation Cable.....	23
6.2 Matters Needing Attention In Single-phase Parallel Operation	23
6.3 Single-phase Parallel Operation Cable Connection.....	24
6.4 Matters Needing Attention In Three-phase Parallel Operation.....	26
6.5 Three-phase Parallel Operation Cable Connection	27
7. Faults Code	32
8. Warning Code	32
9. Parallel Faults Code	33
10. Trouble Shooting	34
11. Specifications	37
11.1 Line Mode Specifications	37
11.2 Inverter Mode Specifications	38
11.3 Charge Mode Specifications	39
11.4 General Specifications	40
12. Installation Dimension Drawing	40

1.About This

1.1 Manual Purpose

This manual describes the assembly, installation, operation and troubleshooting of this unit. Please read this manual carefully before installations and operations. Keep this manual for future reference.

1.2 Scope

This manual provides safety and installation guidelines as well as information on tools and wiring.

2.Safety Instructions

⚠ WARNING: This chapter contains important safety and operating instructions. Read and keep this manual for future reference.

- 1.Before using the unit, read all instructions and cautionary markings on the unit, the batteries and all appropriate sections of this manual.
2. **CAUTION:** The default setting of battery type is AGM battery .If charge other types of batteries,need set up according to the battery features, otherwise may cause personal injury and damage.
- 3.Do not disassemble the unit. Take it to a qualified service center when service or repair is required. Incorrect re-assembly may result in a risk of electric shock or fire.
- 4.To reduce risk of electric shock, disconnect all wire before attempting any maintenance or cleaning. Turning off the unit will not reduce this risk.
- 5.**CAUTION** – Only qualified personnel can install this device with battery.
- 6.**NEVER** charge a frozen battery.
- 7.For optimum operation of this inverter/charger, please follow required spec to select appropriate cable size. It's very important to correctly operate this inverter/charger.
- 8.Be very cautious when working with metal tools on or around batteries. A potential risk exists to drop a tool to spark or short circuit batteries or other electrical parts and could cause an explosion.
- 9.Please strictly follow installation procedure when you want to disconnect AC or DC terminals. Please refer to INSTALLATION section of this manual for the details.
- 10.Fuses are provided as over-current protection for the battery supply.
- 11.GROUNDING INSTRUCTIONS -This inverter/charger should be connected to a permanent grounded wiring system. Be sure to comply with local requirements and regulation to install this inverter.
12. NEVER cause AC output and DC input short circuited. Do NOT connect to the mains when DC input short circuits.
- 13.**Warning!!** Only qualified service persons are able to service this device. If errors still persist after following troubleshooting table, please send this inverter/charger back to local dealer or service center for maintenance.
14. **WARNING:** Because this inverter is non-isolated, only three types of PV modules are acceptable: single crystalline, poly crystalline with class A-rated and CIGS modules. To avoid any malfunction, do not connect any PV modules with possible current leakage to the inverter. For example, grounded PV modules will cause current leakage to the inverter. When using CIGS modules, please be sure NO grounding.
15. **CAUTION:** It's required to use PV junction box with surge protection. Otherwise, it will cause damage on inverter when lightning occurs on PV modules.

3. Introduction

This is a multi-function inverter, combining functions of inverter, solar charger and battery charger to offer uninterruptible power support in a single package. The comprehensive LCD display offers user-configurable and easy-accessible button operations such as battery charging current, AC or solar charging priority, and acceptable input voltage based on different applications.

3.1 Features

1. ON/Off grid inverter
2. Pure sine wave inverter
3. External WIFI devices (APP is required)
4. Support the selection of wide and narrow range of AC input.
5. Configurable AC/Solar charger priority via LCD control panel
6. Configurable battery charging current based on applications via LCD control panel
7. Compatible to utility mains or generator power
8. Auto restart while AC is recovering
9. Overload / Over temperature / short circuit protection
10. Cold start function

3.2 Basic System Architecture

The following illustration shows basic application for this unit. It also required the following devices to have a complete running system:

- Generator or Utility mains.
- PV modules

Consult with your system integrator for other possible system architectures depending on your requirements. This inverter can power various appliances in home or office environment, including motor-type appliances such as tube light, fan, refrigerator and air conditioners.

NOTE: The following picture is only a schematic diagram of the equipment .If the actual chassis does not conform to the schematic due to a structural upgrade, it is subject to prior notice.

Figure 1 Basic hybrid PV System Overview

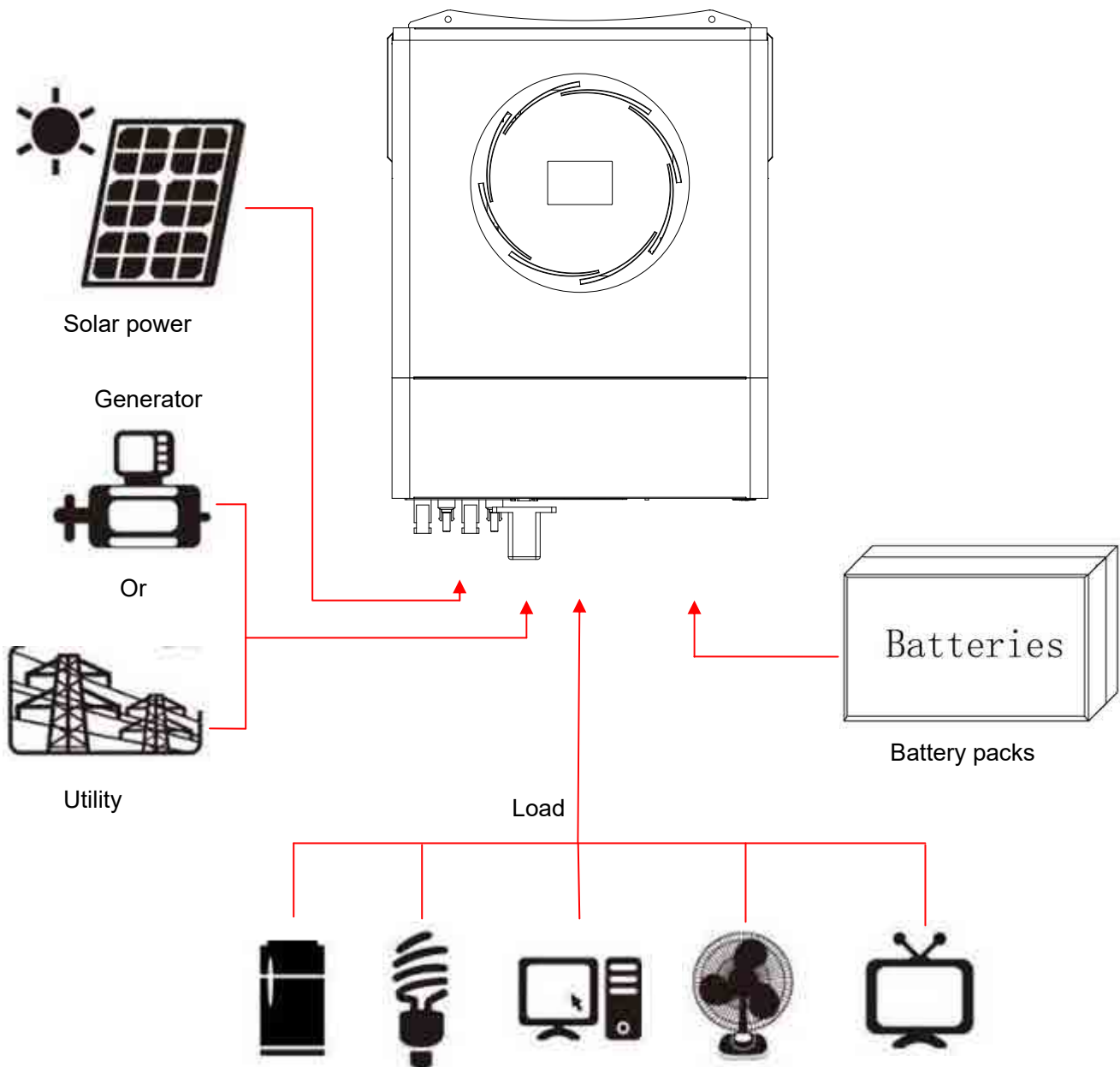

3.3 Product Overview

NOTE: The following picture is only a schematic diagram of the equipment .If the actual chassis does not conform to the schematic due to a structural upgrade, it is subject to prior notice.

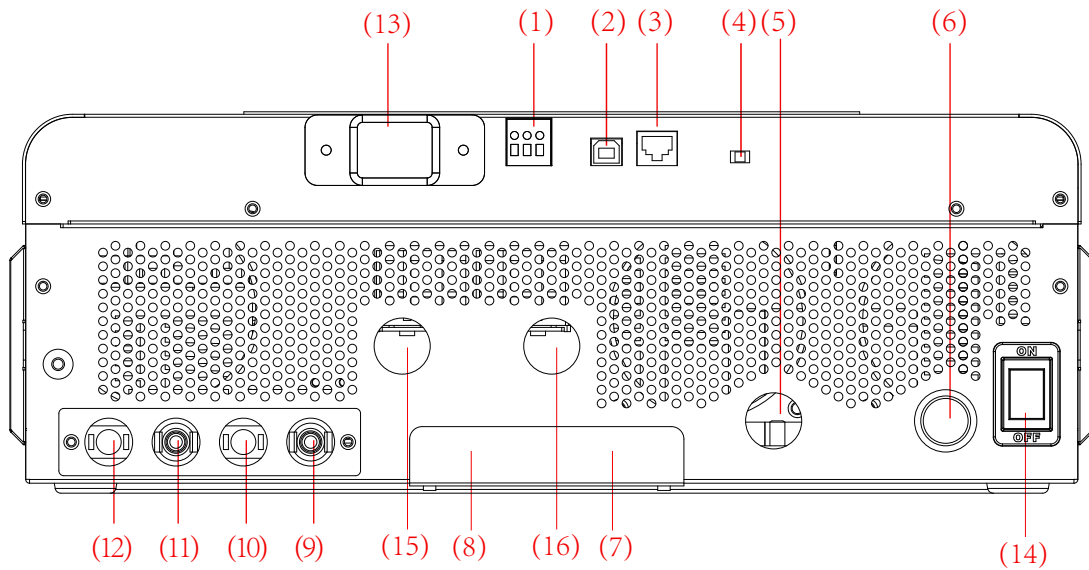

- | | |
|----------------------------|----------------------------|
| 1: Generator dry contact | 2: USB port |
| 3: BMS Port(Reserved) | 4: RGB ON/OFF |
| 5: Battery positive | 6: Battery negative |
| 7: Parallel port | 8: Current sharing port |
| 9: PV1 negative connector | 10: PV1 positive connector |
| 11: PV2 negative connector | 12: PV2 positive connector |
| 13: WIFI port | 14: Power on/off switch |
| 15:AC input connector | 16: AC output connector |

RGB:

- 1、 Battery mode: green, flash
- 2、 Battery+AC mode (in charging): Green / Cyan, flash
- 3、 Battery+AC mode (full charged): Cyan, always light on
- 4、 Battery +Solar mode (in charging): Blue / green or blue / cyan, flash
- 5、 Battery +Solar mode (full charged): blue always light on and cyan flash.

4. Installation

4.1 Unpacking And Inspection

Before installation, please inspect the unit. Be sure that nothing inside the package is damaged. You should have received the following items inside of package:

The inverter x1

User manual x 1

USB Communication cable x1

4.2 Preparation

Before connecting all wire, please take off bottom cover by removing two screws.

NOTE: The following picture is only a schematic diagram of the equipment. If the actual chassis does not conform to the schematic due to a structural upgrade, it is subject to prior notice.

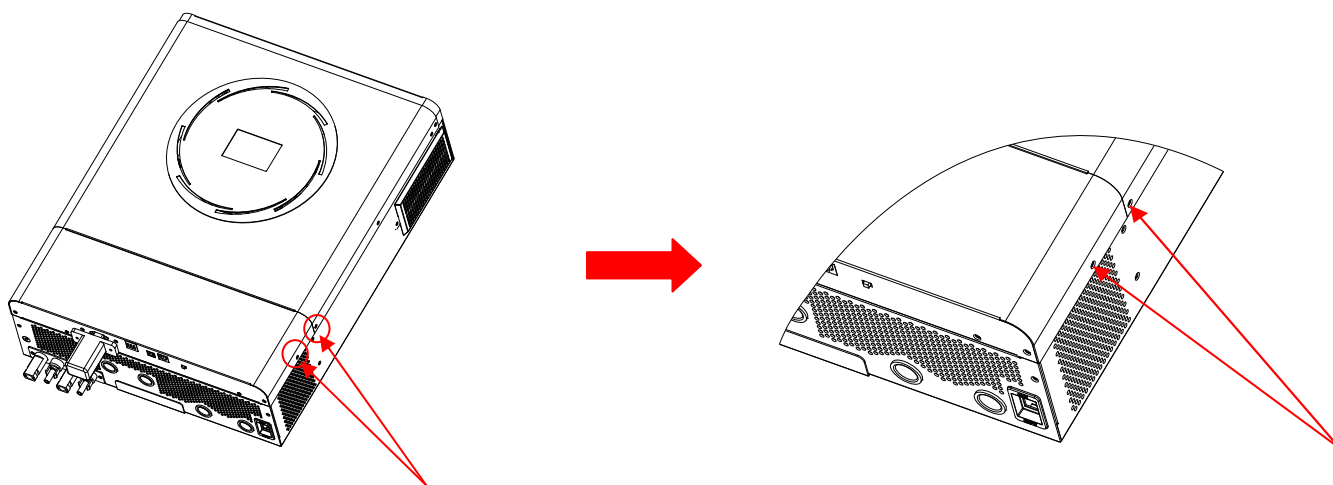

4.3 Mounting The Unit

Consider the following points before selecting where to install:

1. Do not mount the inverter on flammable construction materials.
2. Mount on a solid surface
3. Install this inverter at eye level in order to allow the LCD display to be read at all times.
4. The ambient temperature should be between -10°C and 55°C to ensure optimal operation.
5. The recommended installation position is to be adhered to the wall vertically.
6. Be sure to keep other objects and surfaces as shown in the right diagram to guarantee sufficient heat dissipation and to have enough space for removing wires.

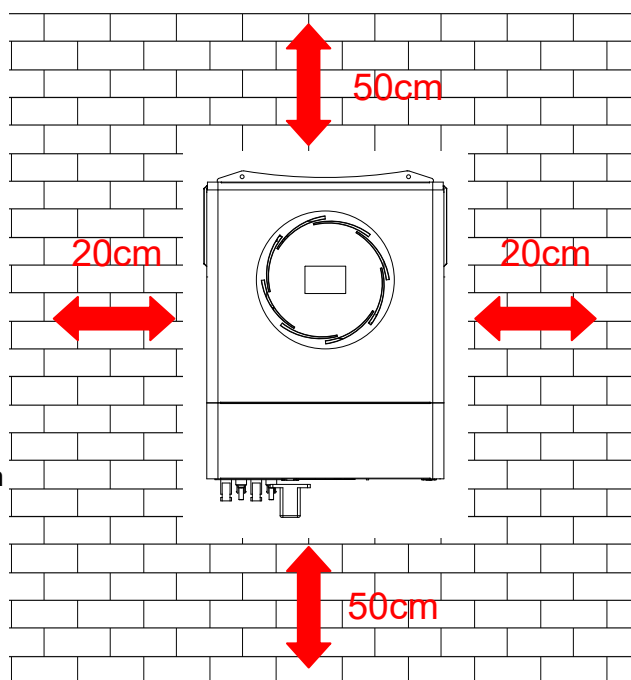

WARNING: SUITABLE FOR MOUNTING ON CONCRETE OR OTHER NON-COMBUSTIBLE SURFACE ONLY.

Install the unit by screwing four screws. It's recommended to use M4 or M5 screws.

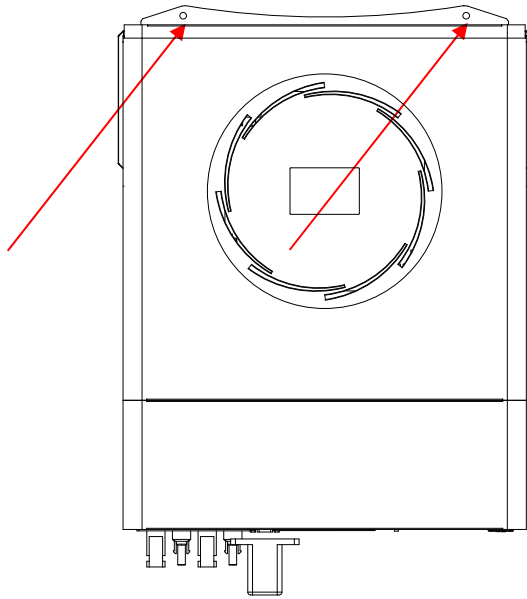

4.4 Battery Connection

CAUTION: For safety operation and regulation compliance, it's requested to install a separate DC over-current protector or disconnect device between battery and inverter. It may not be requested to have a disconnect device in some applications, however, it's still requested to have over-current protection installed. Please refer to typical amperage in below table as required fuse or breaker size.

WARNING! All wiring must be performed by a qualified personnel.

WARNING! It's very important for system safety and efficient operation to use appropriate cable for battery connection. To reduce risk of injury, please use the proper recommended cable and terminal size as below.

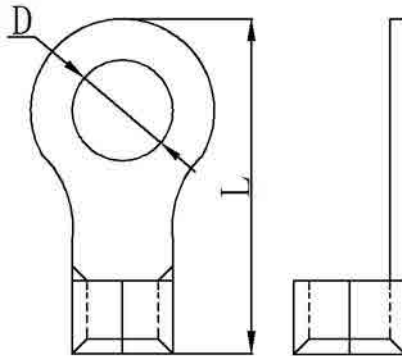

Recommended battery cable and terminal size:

Ring terminal:

Model	Typical Amperage	Battery capacity	Wire Size	Cable mm ²	Ring Terminal Dimensions		Torque value	Length
					D (mm)	L (mm)		
8KW	190.5A	100AH	1AWG	50	8.4	51	5 Nm	1M
		200AH	1/0AWG	70				

Please follow below steps to implement battery connection:

1. Assemble battery ring terminal based on recommended battery cable and terminal size.
2. Fix two cable glands into positive and negative terminals.

48VDC battery connection diagram

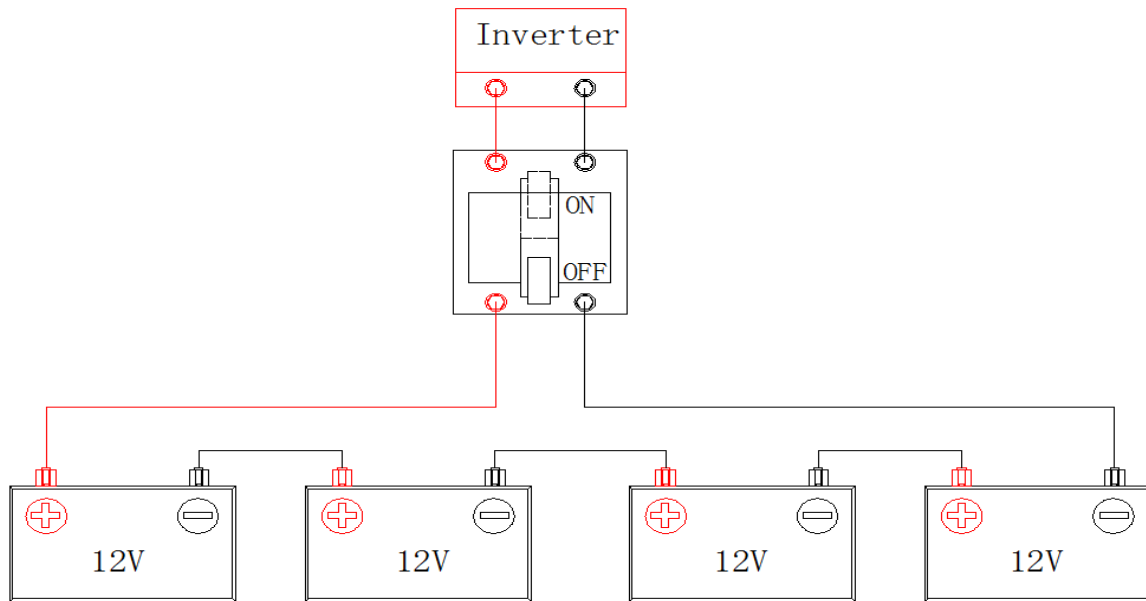

3. Insert the ring terminal of battery cable flatly into battery connector of inverter and make sure the nuts are tightened with torque of 5 Nm. Make sure polarity at both the battery and the inverter/charge is correctly connected and ring terminals are tightly screwed to the battery terminals.

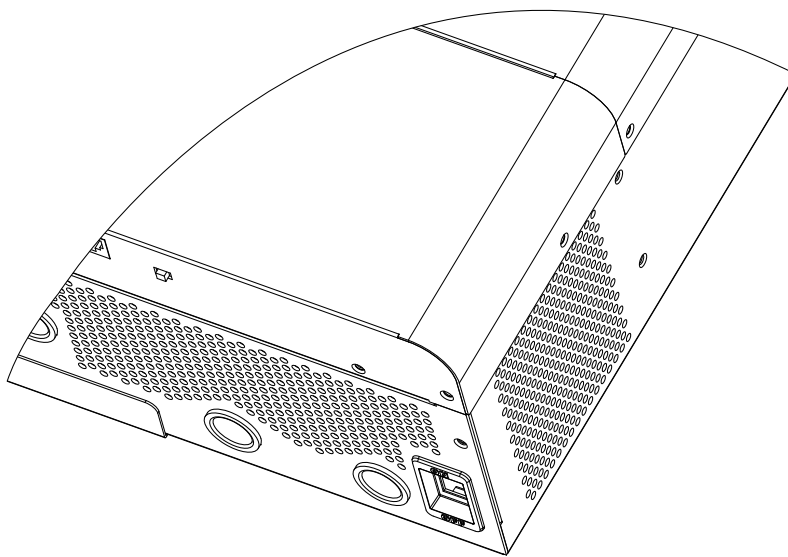

WARNING: Shock Hazard

Installation must be performed with care due to high battery voltage in series

CAUTION!!! Do not place anything between the flat part of the inverter terminal and the ring terminal.

Otherwise, overheating may occur.

CAUTION!!! Do not apply anti-oxidant substance on the terminals before terminals are connected tightly.

CAUTION!!! Before making the final DC connection be sure positive (+) must be connected to positive (+) and negative (-) must be connected to negative(-).

4.5 AC Input/output Connection

CAUTION!! Before connecting to AC input power source, please install a separate AC breaker between inverter and AC input power source. This will ensure the inverter can be securely disconnected during maintenance and fully protected from over current of AC input.

CAUTION!! Please refer to the input and output screen on the machine before wiring, make sure correct wiring.

WARNING! All wiring must be performed by a qualified personnel.

WARNING! It's very important for system safety and efficient operation to use appropriate cable for AC input connection. To reduce risk of injury, please use the proper recommended cable size as below. **Suggested cable requirement for AC wires**

Model	Gauge	Torque Value
8KW	8 AWG	1.4~ 1.6Nm

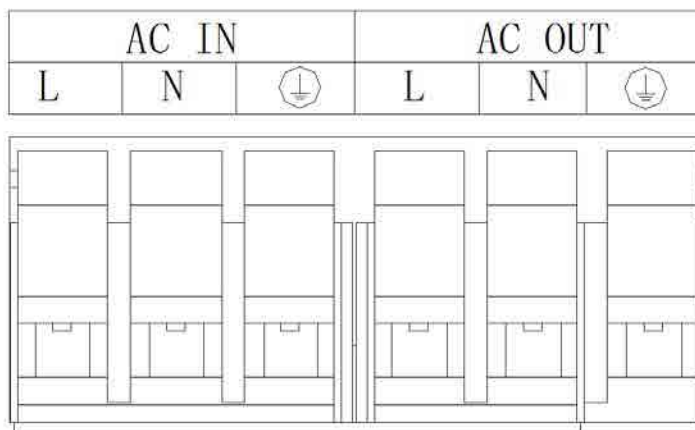

Please follow below steps to implement AC input/output connection:

1. Before making AC input/output connection, be sure to protector disconnected first.
2. Remove insulation sleeve 10mm for six conductors. And shorten phase L and neutral conductor N 3 mm.
3. Fix two cable glands into input and output sides.
4. Insert AC input wires according to polarities indicated on terminal block and tighten the terminal screws.

Be sure to connect PE protective conductor (⊥) first.

⊥ → **Ground (yellow-green)**

L → **LINE (brown or black)**

N → **Neutral (blue)**

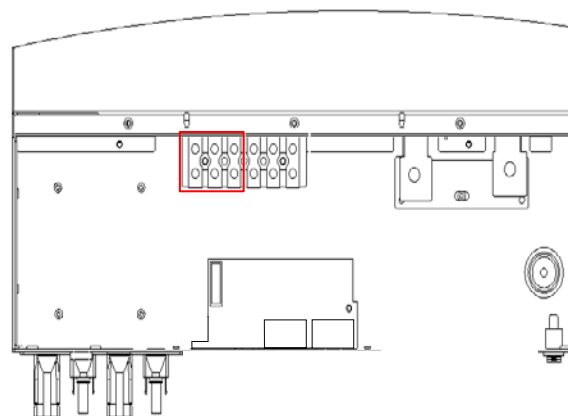
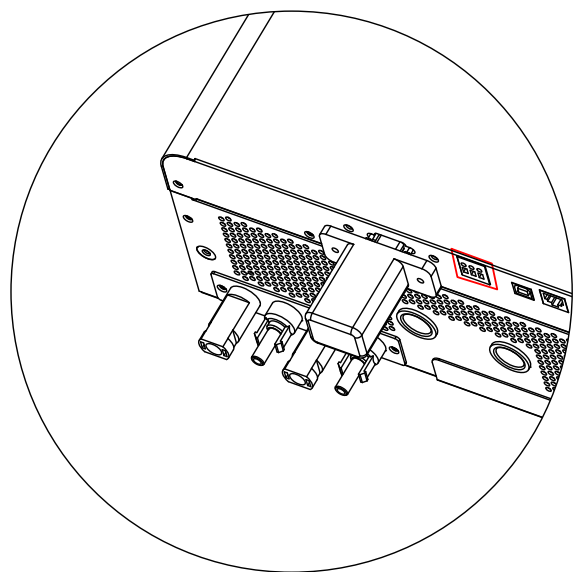

WARNING:

Be sure that AC power source is disconnected before connect wire to the unit.

5. Then, insert AC output wires according to polarities indicated on terminal block and tighten terminal screws. Be sure to connect PE protective conductor (⊕) first.

⊕→Ground (yellow-green)

L→LINE (brown or black)

N→Neutral (blue)

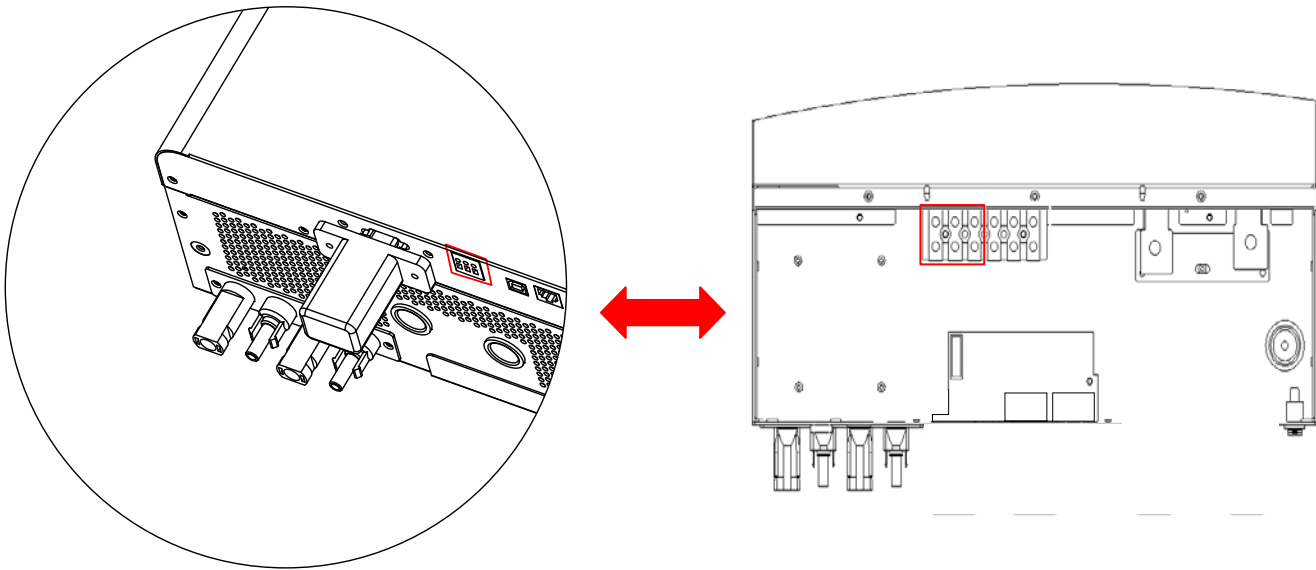

6. Make sure the wires are securely connected.

CAUTION: Important

Be sure to connect AC wires with correct polarity. If L and N wires are connected reversely, it may cause utility short-circuited when these inverters are worked in parallel operation.

CAUTION: Appliances such as air conditioner requires at least 2~3 minutes to restart because it's required to have enough time to balance refrigerant gas inside of circuits. If a power shortage occurs and recovers in a short time, it will cause damage to your connected appliances. To prevent this kind of damage, please check manufacturer of air conditioner if it's equipped with time-delay function before installation. Otherwise, this inverter/charger will be trigger overload fault and cut off output to protect your appliance but sometimes it still causes internal damage to the air conditioner.

4.6 PV Connection

CAUTION: Before connecting to PV modules, please install separately DC circuit breakers between inverter and PV modules.

CAUTION: It is forbidden for inverter to share the same solar panel group.

NOTE1: Please use 600Vdc/30A circuit breaker.

NOTE2: The overvoltage category of the PV input is II.

Please follow the steps below to implement PV module connection:

WARNING: Because this inverter is non-isolated, only three types of PV modules are acceptable: single crystalline and poly crystalline with class A-rated and CIGS modules.

To avoid any malfunction, do not connect any PV modules with possible current leakage to the inverter. For example, grounded PV modules will cause current leakage to the inverter. When using CIGS modules, please be sure NO grounding.

CAUTION: It's required to use PV junction box with surge protection. Otherwise, it will cause damage on inverter when PV modules are struck by lightning.

Step 1: Check the input voltage of PV array modules. This system is applied with two strings of PV array. Please make sure that the maximum current load of each PV input connector is 18A.

CAUTION: Exceeding the maximum input voltage can destroy the unit!! Check the system before wire connection.

Step 2: Disconnect the circuit breaker and switch off the DC switch.

Step 3: Assemble provided PV connectors with PV modules by the following steps.

Components for PV connectors and Tools:

Female connector housing	
Female terminal	
Male connector housing	
Male terminal	
Crimping tool and spanner	

Prepare the cable and follow the connector assembly process:

Strip one cable 8 mm on both end sides and be careful NOT to nick conductors.



Insert striped cable into female terminal and crimp female terminal as shown below.



Insert assembled cable into female connector housing as shown below.



Insert striped cable into male terminal and crimp male terminal as shown below.



Insert assembled cable into male connector housing as shown below.



Step 4: Check correct polarity of connection cable from PV modules and PV input connectors. Then, connect positive pole (+) of connection cable to positive pole (+) of PV input connector. Connect negative pole (-) of connection cable to negative pole (-) of PV input connector.

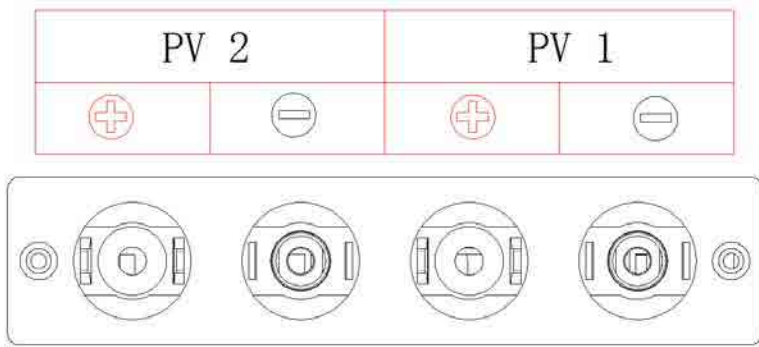

WARNING! For safety and efficiency, it's very important to use appropriate cables for PV module connection. To reduce risk of injury, please use the proper cable size as recommended below.

Model	Cable (mm ²)	AWG	Torque value(max)
8KW	4	12	1.2-1.6 Nm

CAUTION: Never directly touch the terminals of inverter. It might cause lethal electric shock.

PV1 Connection

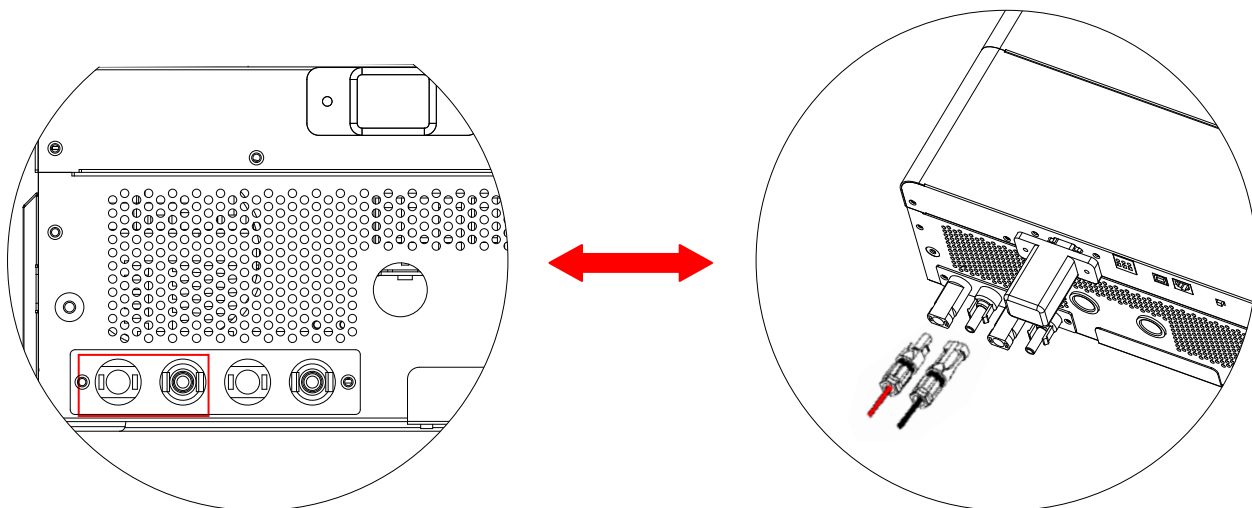

PV2 Connection

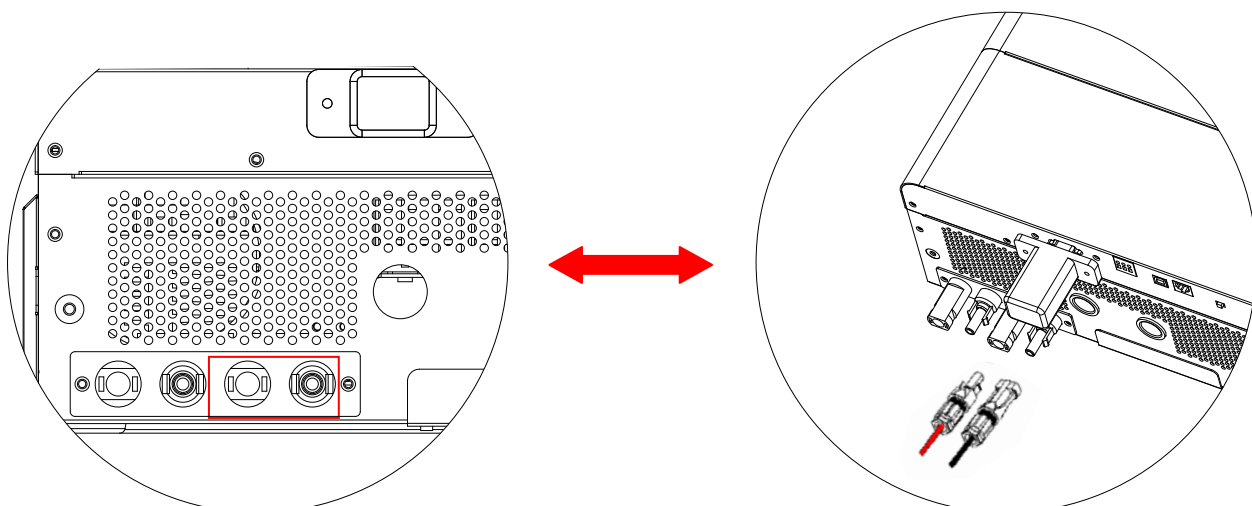

Recommended Panel Configuration

When selecting proper PV modules, please be sure to consider the following parameters:

1. Open circuit Voltage (Voc) of PV modules not to exceed maximum PV array open circuit voltage of the inverter.
2. Open circuit Voltage (Voc) of PV modules should be higher than the start-up voltage.

INVERTER MODEL	8KW
Max. PV Array Power	4000W*2
Max. PV Array Open Circuit Voltage	450Vdc
PV Array MPPT Voltage Range	120Vdc~450Vdc

Recommended solar panel configuration:

	SOLAR INPUT 1	SOLAR INPUT 2	Q'ty of panels	Total Input Power
	Min. in series: 4pcs, per input Max. in series: 12pcs, per input			
Solar Panel Spec. (reference) - 250Wp - Vmp: 30.7Vdc - Imp: 8.3A - Voc: 36Vdc - Isc: 8.4A - Cells: 60	4pcs in series	x	4pcs	1000W
	x	4pcs in series	4pcs	1000W
	12pcs in series	x	12pcs	3000W
	x	12pcs in series	12pcs	3000W
	6pcs in series	6pcs in series	12pcs	3000W
	6pcs in series, 2 strings	x	12pcs	3000W
	x	6pcs in series, 2 strings	12pcs	3000W
	8pcs in series, 2 strings	x	16pcs	4000W
	x	8pcs in series, 2 strings	16pcs	4000W
	9pcs in series, 1 string	9pcs in series, 1 string	18pcs	4500W
	10pcs in series, 1 string	10pcs in series, 1 string	20pcs	5000W
	12pcs in series, 1 string	12pcs in series, 1 string	24pcs	6000W
	6pcs in series, 2 strings	6pcs in series, 2 strings	24pcs	6000W
	7pcs in series, 2 strings	7pcs in series, 2 strings	28pcs	7000W
8pcs in series, 2 strings	8pcs in series, 2 strings	32pcs	8000W	

4.7 Final Assembly

After connecting all wirings, re-connect three cables and then put bottom cover back by screwing two screws as shown below.

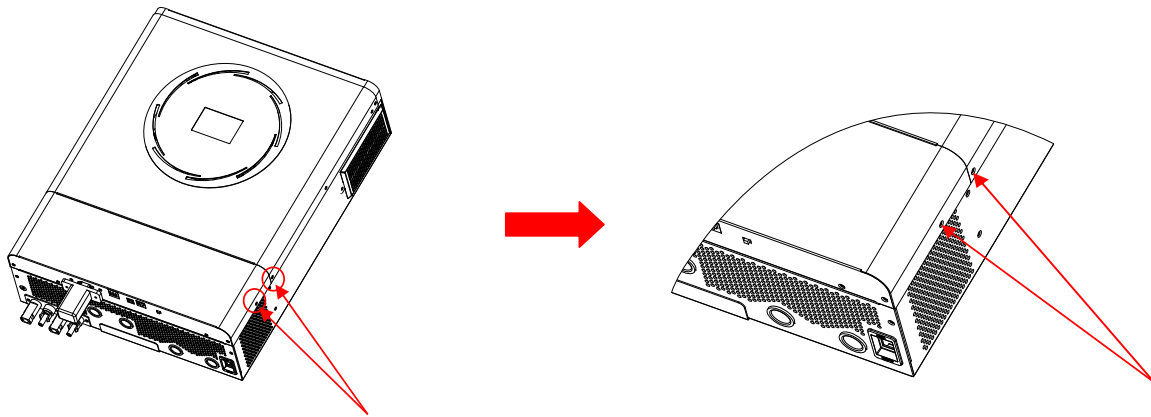

4.8 RS232/USB Communication Connection

Please download software “SolarPower” from the official website. When the inverter is connected to the computer, the following interface will be displayed.

Note: The following dates are for reference only.

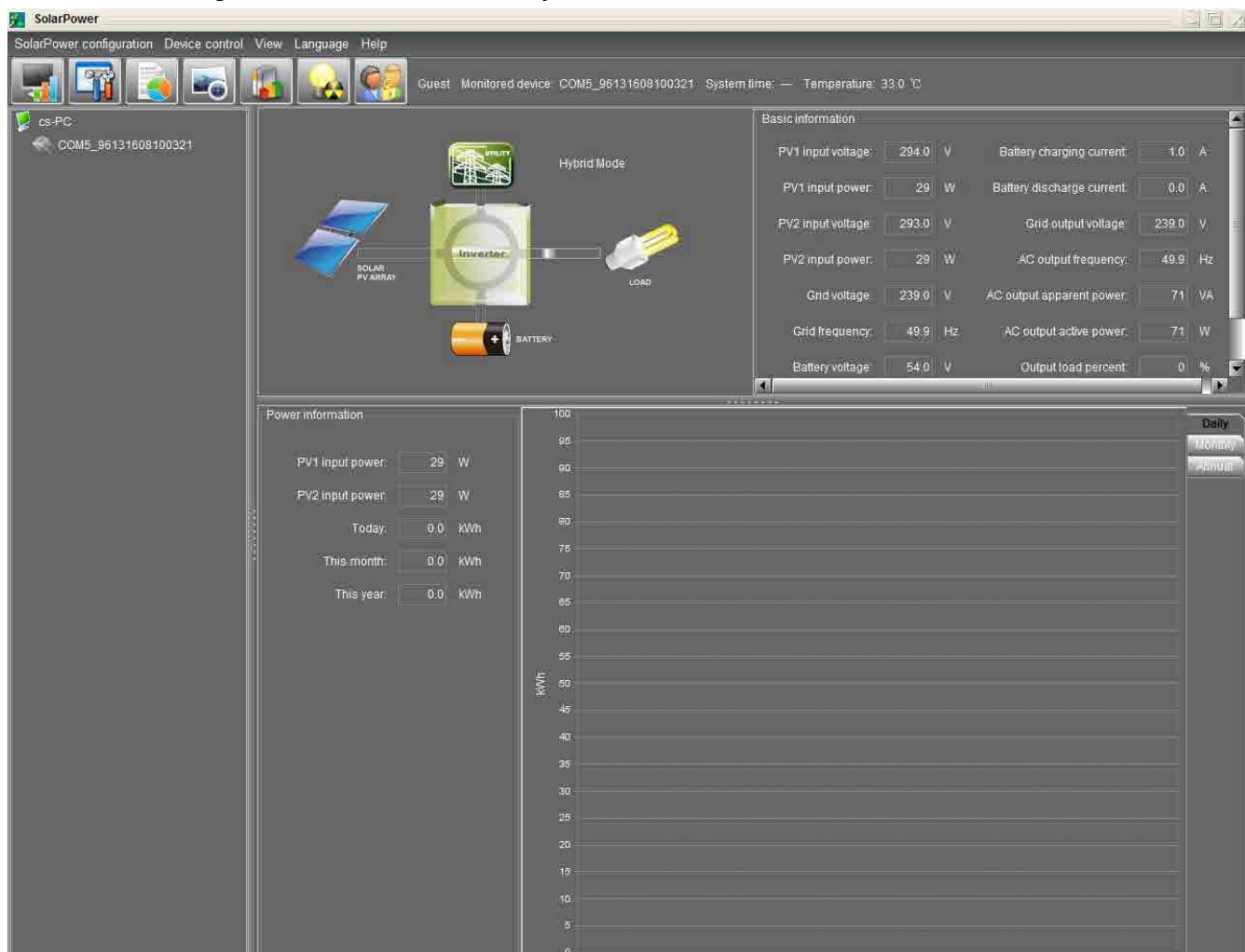

4.9 Wi-Fi Connection (Optional)

1. The device has its own standard WIFI port, if users need to monitor the status and information of the device through WIFI, they must connect to the WIFI collector.
2. Users can download “SmartEss” WIFI monitoring software from the app store on their phone.
3. Inverters come equipped with factory-integrated Wi-Fi capability which makes it very easy to integrate into a home network (Wi-Fi Dongle is Optional) this makes it ideal for local monitoring via the inverter’s own wireless home network or for online monitoring platforms.

4.10 Dry Contact Signal

There is one dry contact (3A250VAC) available on the rear panel. It could be used to deliver signal to external device when battery reaches warning level.

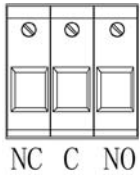
Unit Status	Condition		
		NC & C	C & NO
Power Off	Unit is off and no output is powered	Open	Close
Power On	Battery voltage <Setting the voltage in program 12	Close	Open
	Battery voltage >Setting the voltage in program 13	Open	Close

5. Operation

5.1 Power ON/OFF

Once the unit has been properly installed and the batteries are connected well, simply press On/Off switch (located on the button of the case) to turn on the unit.

5.2 Operation And Display Panel

The operation and display panel, shown in below chart, is on the front panel of the inverter. It includes three indicators, four function keys and a LCD display, indicating the operating status and input/output power information.

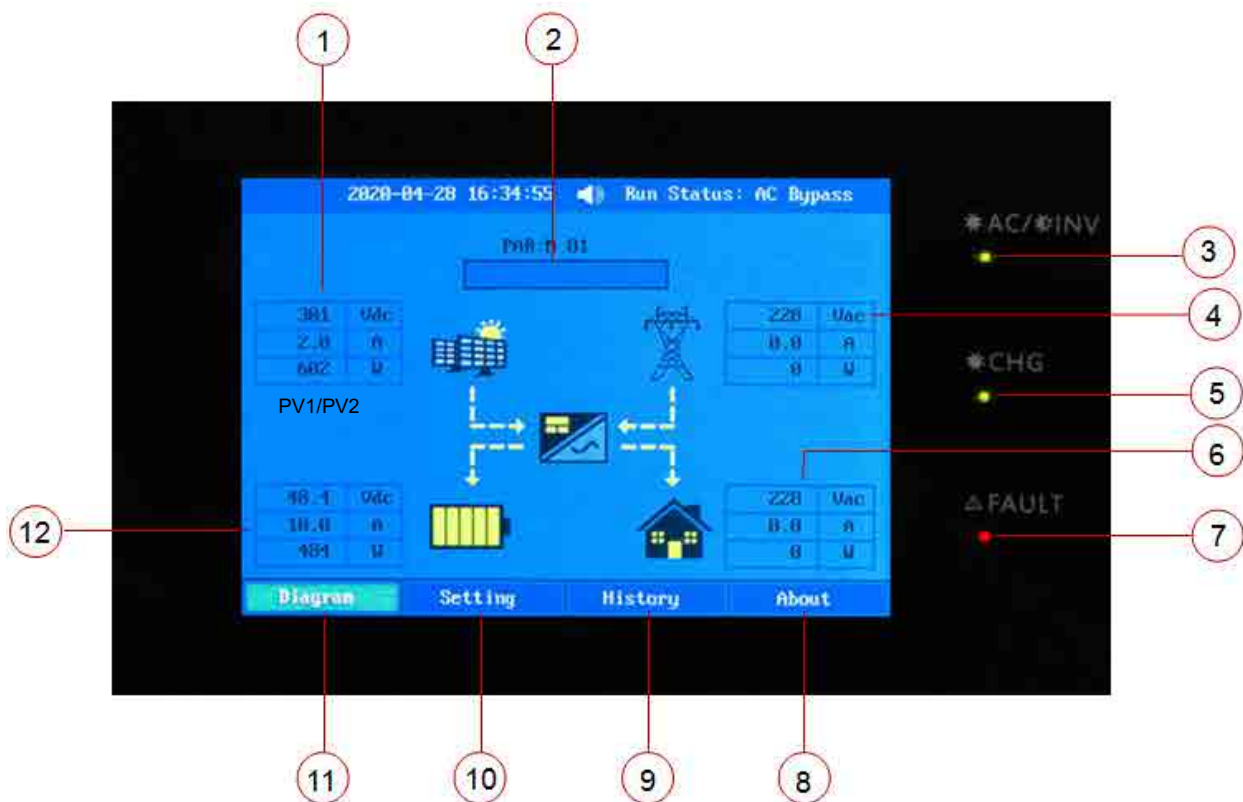





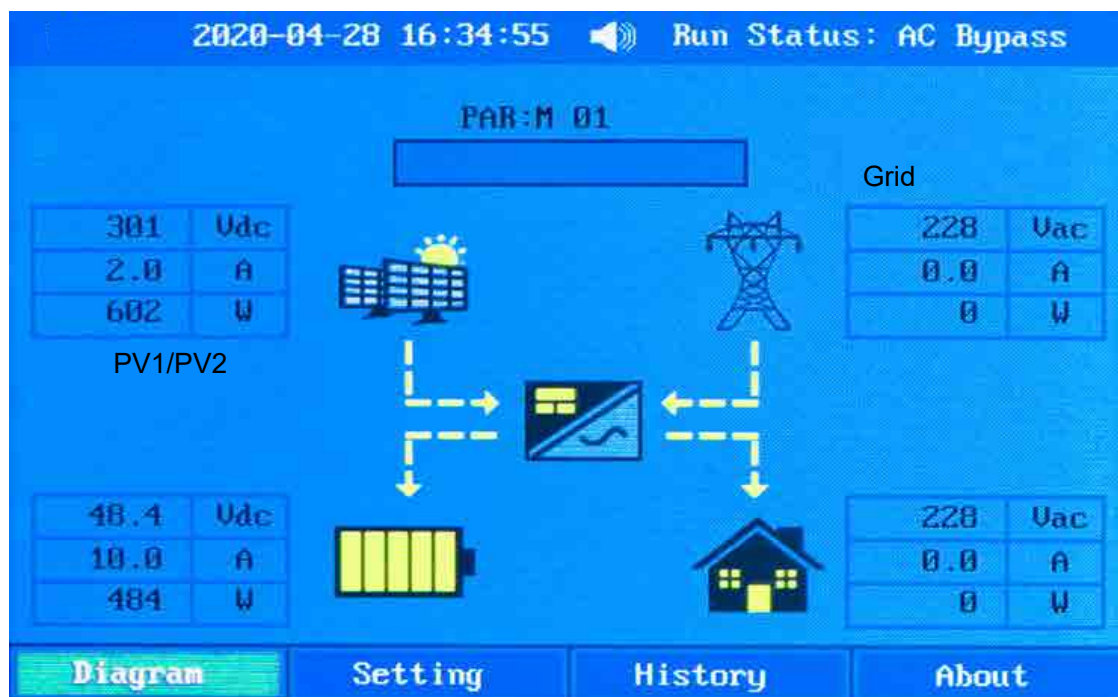

- | | |
|-------------------------|--------------------------|
| 1. PV input information | 2. Operation information |
| 3. AC/INV indicator | 4. AC Input information |
| 5. Charging indicator | 6. AC Output information |
| 7. Fault indicator | 8. About button |
| 9. History button | 10. Setting button |
| 11. Diagram button | 12. Battery information |

5.3 LCD Display Icons





Icon	Description
	operation time
	Operation information include fault and warning code
	Input voltage ,current and power information
	Output voltage ,current and power information
	PV input voltage , PV input current ,PV input power information NOTE: the information of PV1 and PV2 is automatically switched every 3 seconds
	Battery voltage ,current and power information
	Indicates the DC/AC inverter circuit is working
	Parallel status Explain: “PAR”:Parallel mode , “M”:Host, “S”:Slave “01”:Parallel number
	Grid mode is enable



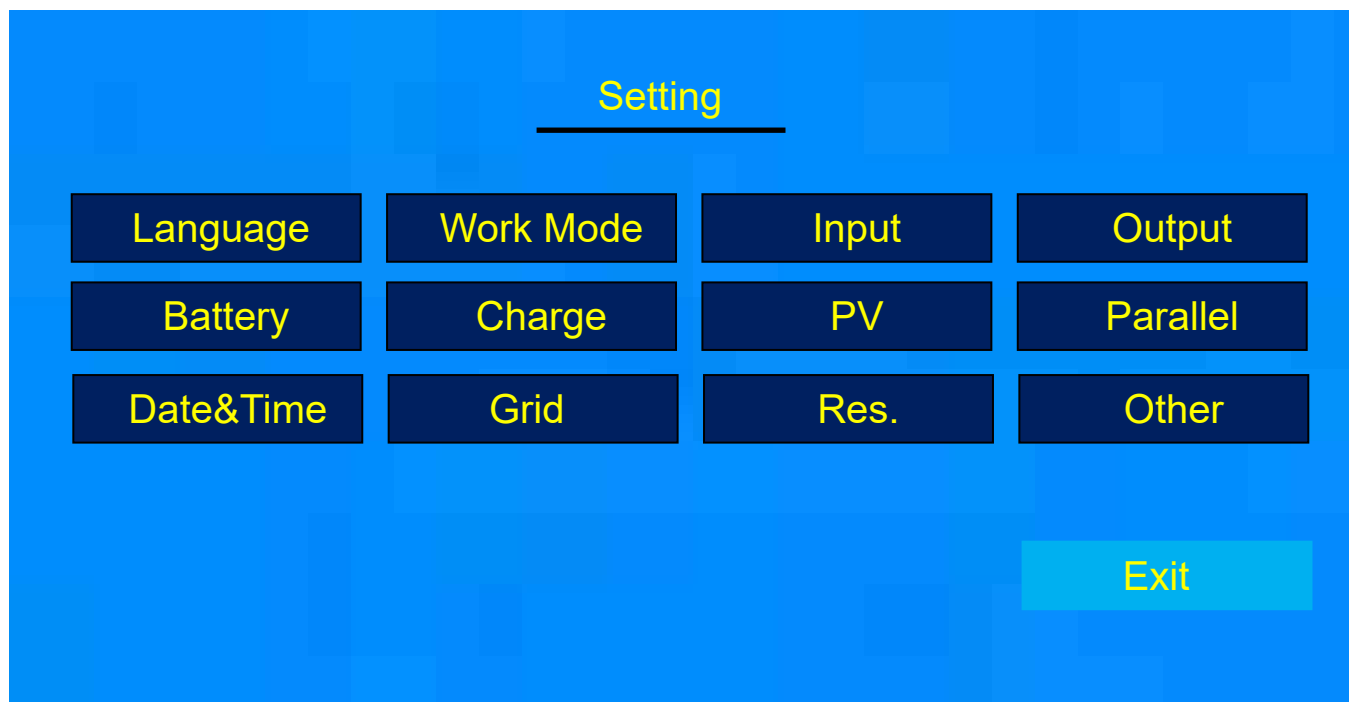

	Inverter working status Battery mode run status: Bat inv Utility mode run status: AC Bypass PV +Utility mode run status: PV+AC
	Volume icon
	LCD Version , Inverter Version, Mppt Version, Machine Type
	This button includes generation, event, help
	language, working mode, input, output , battery, charge, PV, parallel, date and time, Grid, peak valley, and other
	Work state diagram

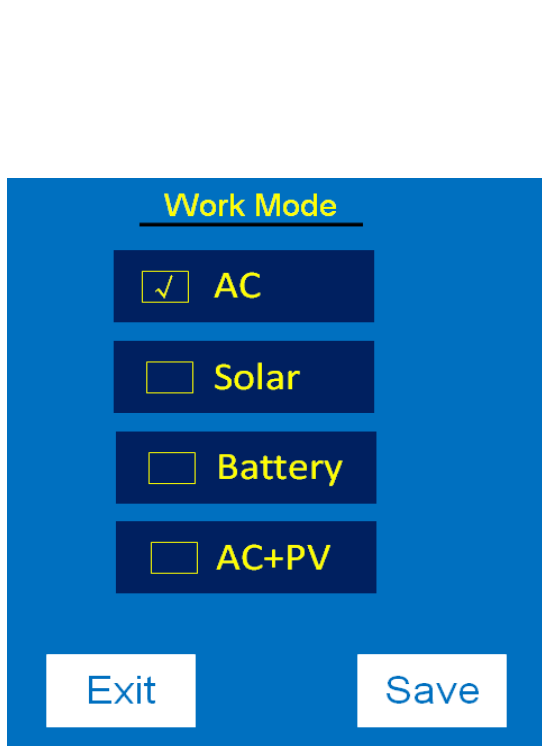
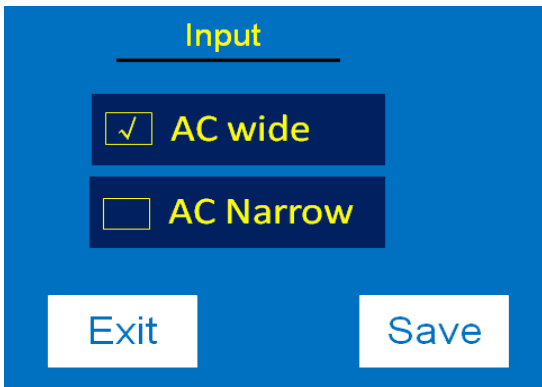

5.4 LCD Setting

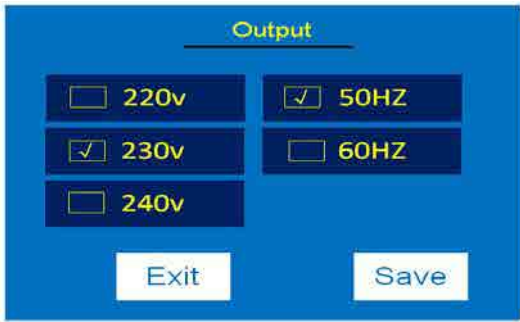
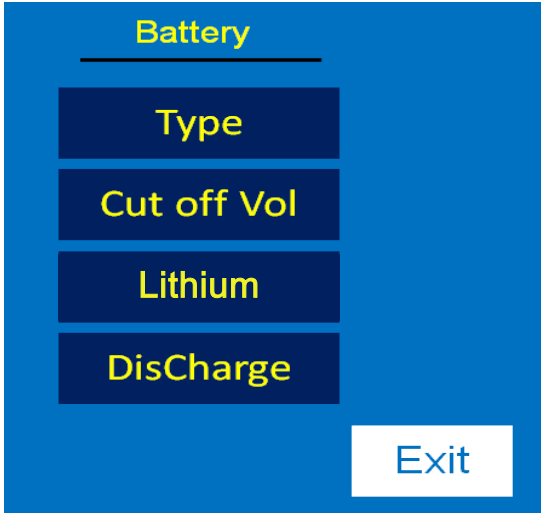

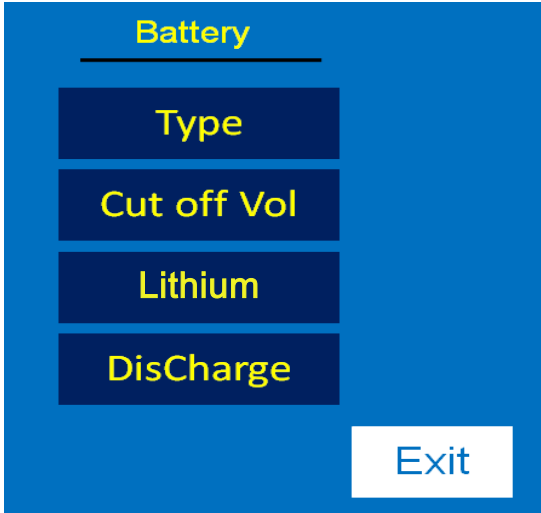
After press function button, the unit will enter setting mode. Set password: 1155



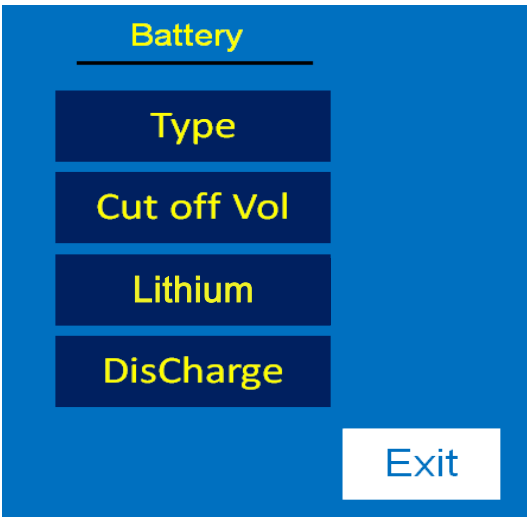
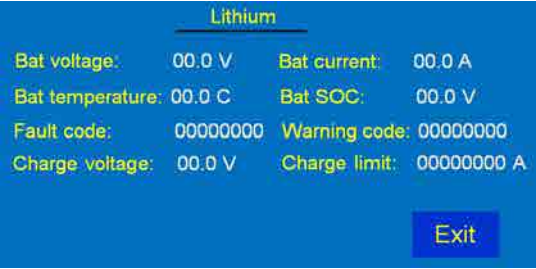
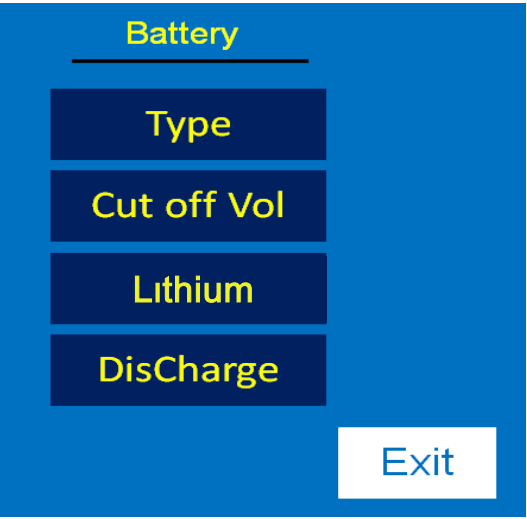
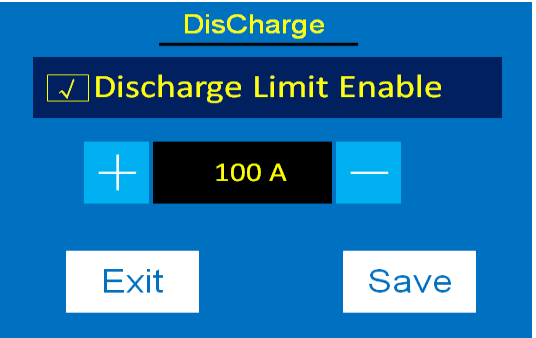
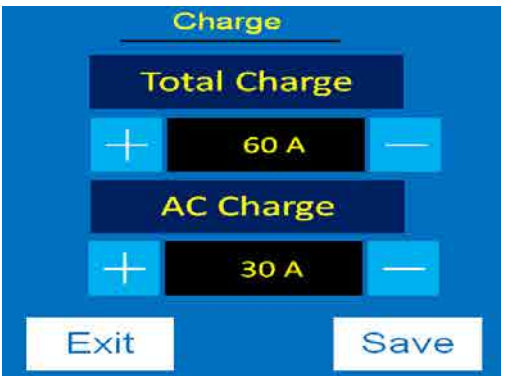



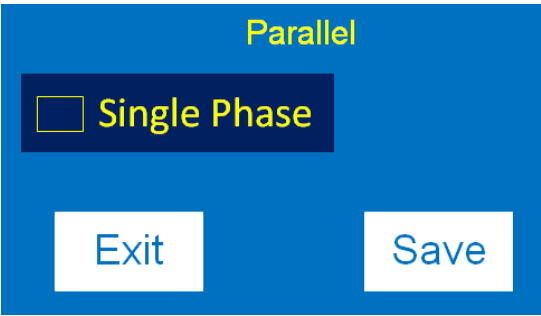
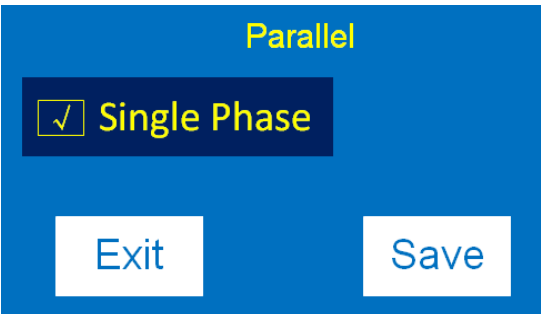
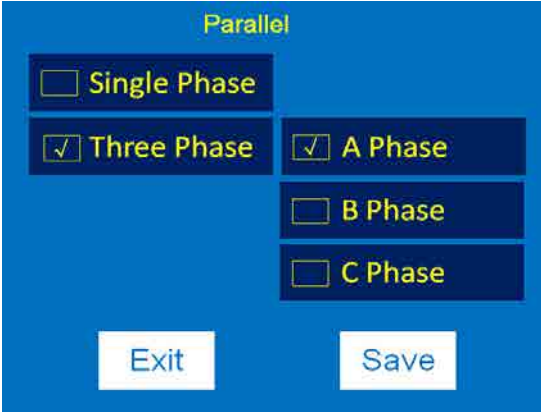

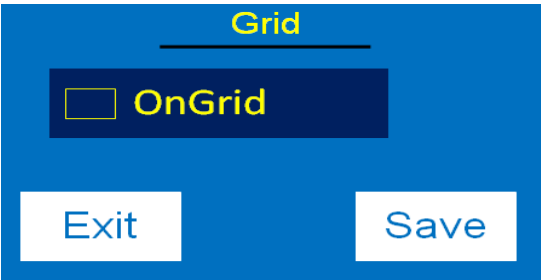
item	menu	description
Language		Default: English
Work Mode		<p>AC :(default) AC will provide power to the loads as the priority, solar charging the battery. When solar energy is insufficient, AC and solar energy charge the battery at the same time. When AC is unavailable, it will be powered by solar energy or batteries.</p> <p>Solar: (option) solar energy provides power to the loads as the priority. When the solar energy is sufficient, the extra energy will charges the battery. When solar energy is insufficient for load, batteries and solar will supplies power the loads at the same time. When solar energy and batteries are insufficient or solar energy is unavailable, AC power to the loads and charge the battery at the same time.</p> <p>Battery: (option) Battery provides power to the loads as the priority. AC provides power to the loads when battery voltage drop to low-level warning voltage or setting point, and the AC power will charge the battery. When the battery is fully charged, battery provides power to the loads again.</p> <p>AC+PV: (option) solar energy provides power to the loads as the priority. If solar energy is not sufficient to power all loads, AC energy will supply power to the loads at the same time.</p>
Input		<p>Wide range : (default) AC input voltage range will be within 90-280VAC.</p> <p>Narrow range: (option) AC input voltage range will be within 170-280VAC.</p>

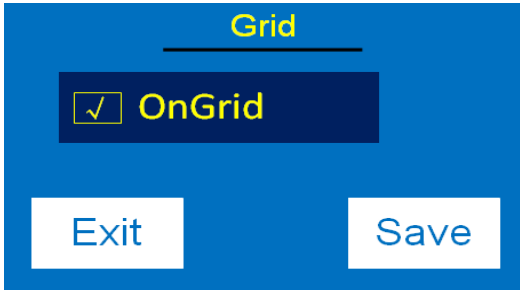
Output		<p>220V(option) 230V(default) 240V(option) 50HZ(default) 60HZ(option)</p>
Battery		 <p>1. Lead acid battery(default) 2. Lithium(option) 3. No Bat: no battery(option) 4. User: (option) 4.1. If "User-Defined" is selected, Bulk charging voltage and Floating charging voltage, setting range: 48.0V to 60V, Increment of each click is 0.1V. 4.2. if you have a lithium battery, you can choose this option. 4.3. if the BMS communication is connected between the inverter and the lithium battery, the display battery icon will display "USER".</p>
Battery		 <p>1. Low Vol Disconnect: Setting voltage point back to utility source when selecting "Solar" or "Battery". setting range :44.0V to 51V, Increment of each click is 0.1V. 2. Shutdown Vol Setting range is from 42.0V to 48.0V. Increment of each click is 0.1V. 3. High Vol Reconnect: Setting voltage point back to battery mode when selecting "Solar" or "Battery" .setting range: 48.0V to 58V, Increment of each click is 0.1V.</p>

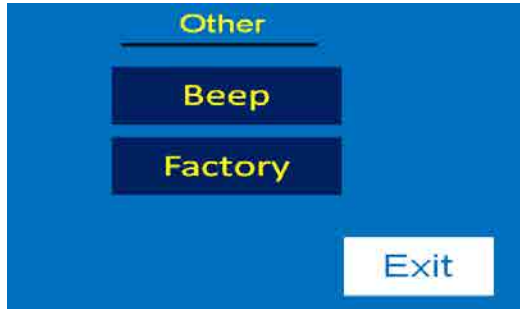
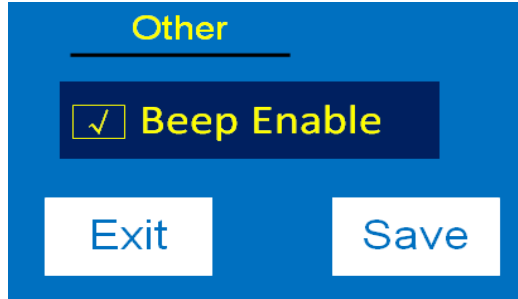
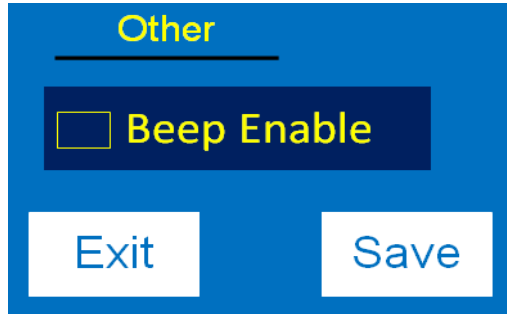
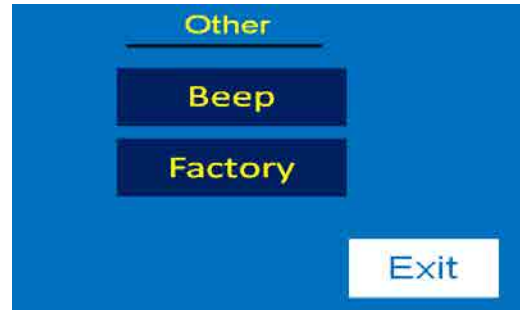
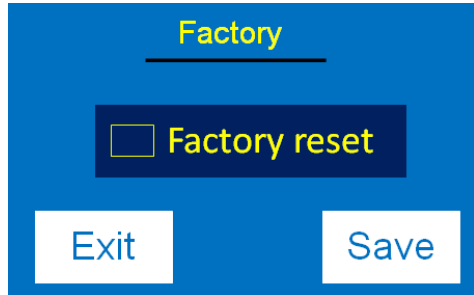
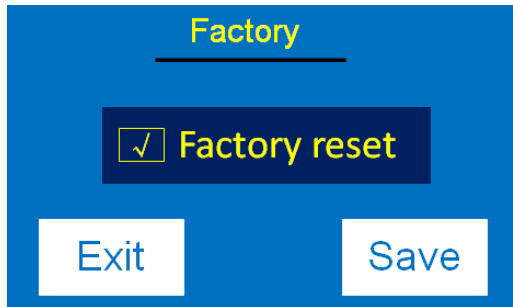
<p>Battery</p>		<p>After the communication connection between the inverter and the lithium battery is successful, you can view the information of the lithium battery</p> 
		 <p>1. discharge current limited disable(default) 2. setting range :10A to 200A setting increase or decrease of 5A. NOTE: if you work in “Solar” or “Battery”, when the loads is greater than the current limiting point, it will automatically switch to utility mode. 3.if it only works in battery mode, when the load is greater than the current limiting point ,the inverter will shut down immediately.</p>
<p>Charge</p>		<p>1.Total Charge:60A(default) Setting range is from 10A to 120A.Increment of each click is 10A. 2.AC Charge: 30A(default) Setting range is from 2A,10A to 120A.Increment of each click is 10A.</p>
<p>PV</p>		<p>PV CAP:(Default 3k)According to the actual capacity of the solar plate, users <input checked="" type="checkbox"/> in and set the rang of 1kva-8kva, the increment or decrement is 0.1k per click.</p>

	 <p>Parallel</p> <p><input type="checkbox"/> Single Phase</p> <p>Exit Save</p>	Stand-alone running mode
Parallel	 <p>Parallel</p> <p><input checked="" type="checkbox"/> Single Phase</p> <p>Exit Save</p>	Single-phase parallel mode Note: This setting is only available when the inverter is in standby mode (Switch off).
	 <p>Parallel</p> <p><input type="checkbox"/> Single Phase</p> <p><input checked="" type="checkbox"/> Three Phase</p> <p><input checked="" type="checkbox"/> A Phase</p> <p><input type="checkbox"/> B Phase</p> <p><input type="checkbox"/> C Phase</p> <p>Exit Save</p>	Three Phase: 1.if users need three-phase parallel ,each device must be set to A/B/C separately. 2.Three-phase parallel needs at least three device to do three-phase parallel run. 3.when three-phase parallel,make sure that A-phase is the host; 4.after the parallel parameters are modified,the device must be restarted to be effective; 5. All inverters must share the same battery pack when paralleling 6.This setting is only available when the inverter is in standby mode (Switch off).
Date & Time	 <p>Date & Time</p> <p>+ 2022 Year -</p> <p>+ 01 Month -</p> <p>+ 15 Day -</p> <p>+ 15 Hour -</p> <p>+ 30 Min -</p> <p>Exit Save</p>	You can set the local date and time in your country
Grid	 <p>Grid</p> <p><input type="checkbox"/> OnGrid</p> <p>Exit Save</p>	OnGrid: disable(default)

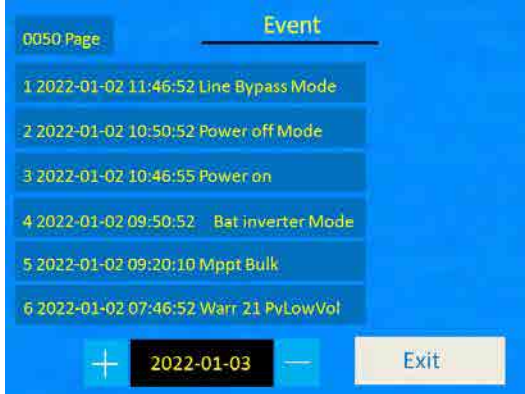
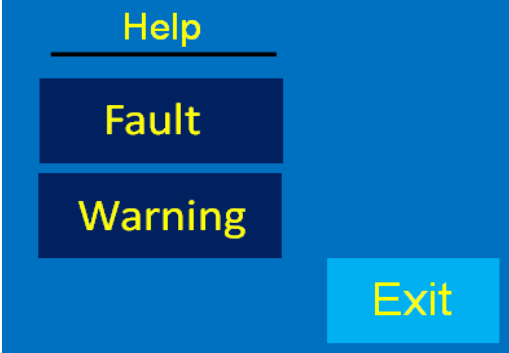
Grid		OnGrid: enable
Res		Alternate menu
Other		<p>Beep Enable(default)</p>  <p>Beep disable: mute</p> 
Other		<p>Factory reset: disable(default)</p>  <p>Factory reset: enable, all parameters are restored to their default values</p> 

<p>History</p>		<p>Generation:the data in the picture is for reference only.</p> 
<p>History</p>		<p>Event:you can view the running record of the device.</p>
<p>History</p>		<p>Help:you can view fault and warning codes.</p>
<p>About</p>		<p>LCD display version Inverter control version Mppt control version Machine type</p>

6. Parallel Installation Guide

6.1 Parallel Operation Cable

1. Recommended battery cable and terminal size for each inverter:

Model	Typical Amperage	Battery capacity	Wire Size	Cable mm ²	Ring Terminal		Torque value	Length
					Dimensions			
					D (mm)	L (mm)		
8KW	190.5A	100AH	1AWG	50	8.4	51	5 Nm	1M
		200AH	1/0AWG	70				

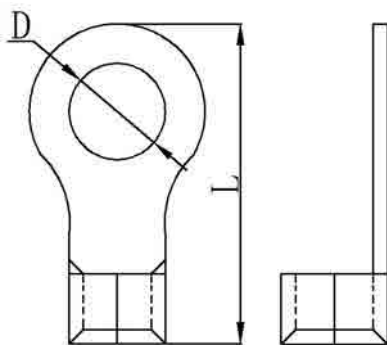

WARNING: Be sure the length of all battery cables is the same. Otherwise, there will be voltage difference between inverter and battery to cause parallel inverters not working.

2. Recommended breaker specification of battery for each inverter:

Model	1 unit*X
8KW	250A70Vdc

If you want to use only one breaker at the battery side for the whole system, the rating of the breaker should be X times current of 1 unit. "X" indicates the number of inverters connected in parallel.

3. Recommended AC input and output cable size for each inverter

Model	Gauge	Torque Value
8KW	8 AWG	1.4~ 1.6Nm

Model	2 units	3 units	4 units	5 units	6units
8KW	120A/230VAC	180A/230VAC	240A/230VAC	300A/230VAC	360A/230VAC

Note 1: Also, you can use 60A breaker with only 1 unit and install one breaker at its AC input in each inverter.

Note 2: Regarding three-phase system, you can use 4-pole breaker directly and the rating of the breaker

WARNING: Regarding AC input and output, please also follow the same principle. should be compatible with the phase current limitation from the phase with maximum units.

6.2 Matters Needing Attention In Single-phase Parallel Operation

1. Parallel operation in single phase with up to 6 units.

2. **WARNING:** It's required to connect battery for parallel operation, it is forbidden to use parallel without batteries

3. **WARNING:** It is forbidden for inverter to share the same solar panel group.

4. **WARNING:** Make sure all cables are of the same length, Otherwise, there will be voltage difference between inverter and battery to cause parallel inverters not working.

5. Set the parameters of each inverter separately (working mode, single - phase parallel function).

Warning: When working in parallel, the working mode of each inverter must be the same working mode, output frequency.

6. After setting the parameters, turn on each inverter in turn.

7. **WARNING:** When running in parallel, all inverters must share the battery pack.

6.3 Single-phase Parallel Operation Cable Connection

1. Two inverters in parallel :

Power Connection:

NOTE: The following picture is only a schematic diagram of the equipment .If the actual chassis does not conform to the schematic due to a structural upgrade, it is subject to prior notice.

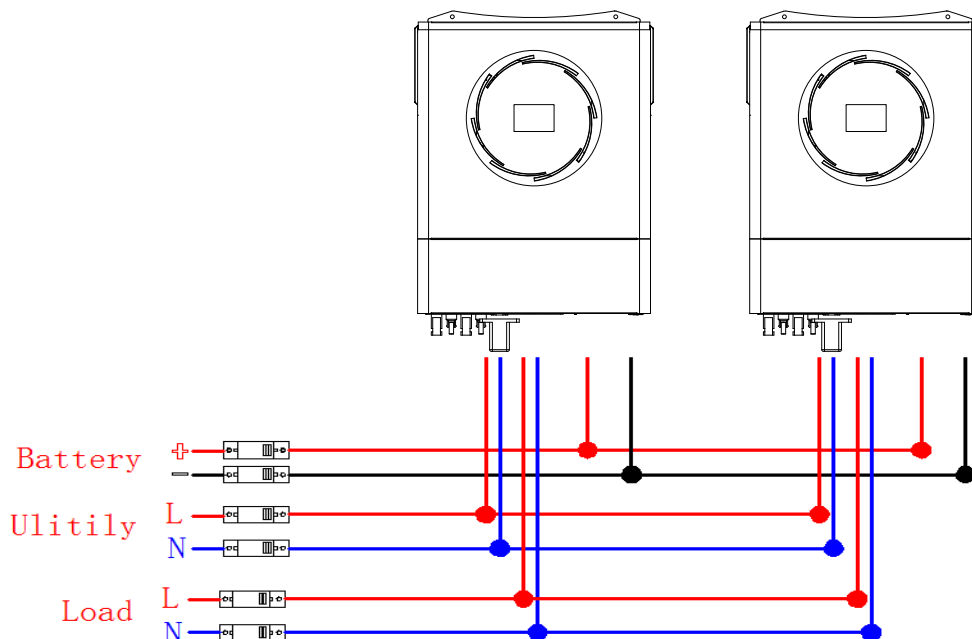

Communication Connection

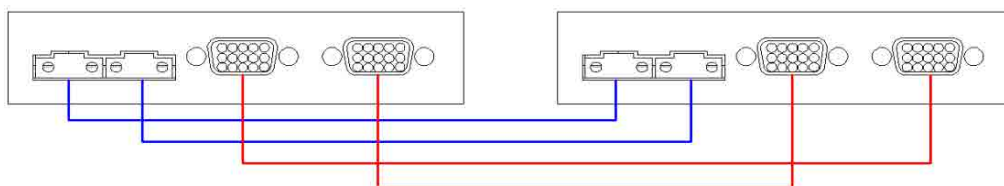

2. Three inverters in parallel :

Power Connection:

NOTE: The following picture is only a schematic diagram of the equipment .If the actual chassis does not conform to the schematic due to a structural upgrade, it is subject to prior notice.

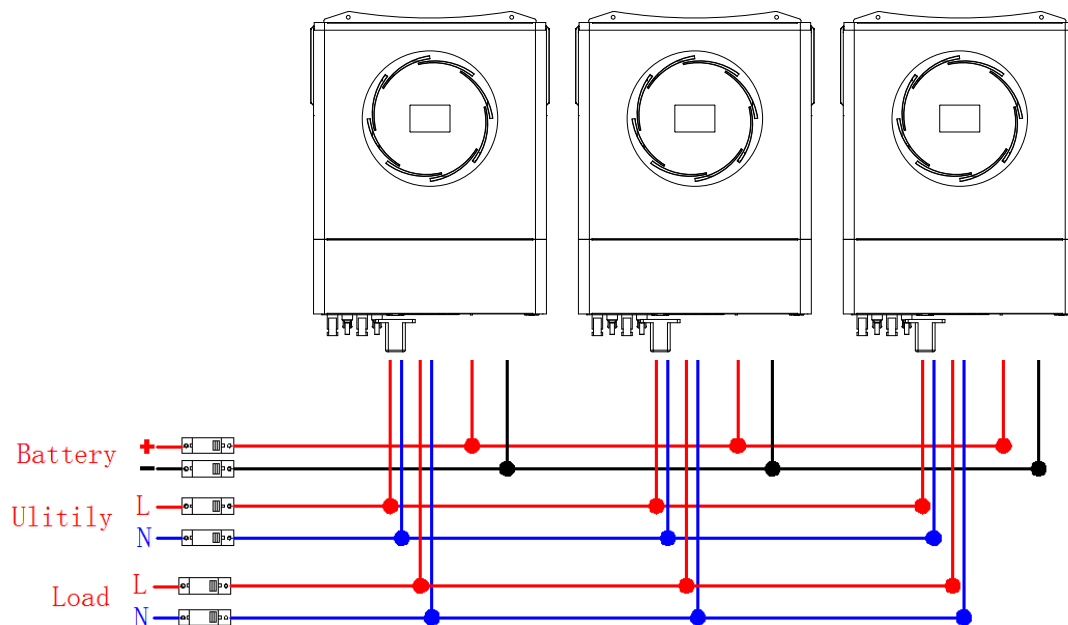

Communication Connection

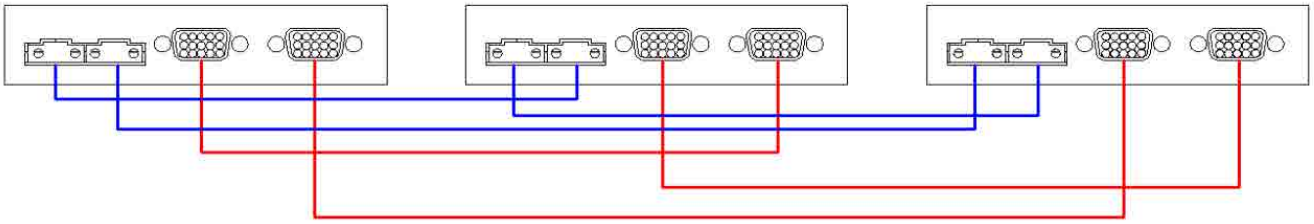

3. Four inverters in parallel :

Power Connection:

NOTE: The following picture is only a schematic diagram of the equipment .If the actual chassis does not conform to the schematic due to a structural upgrade, it is subject to prior notice.

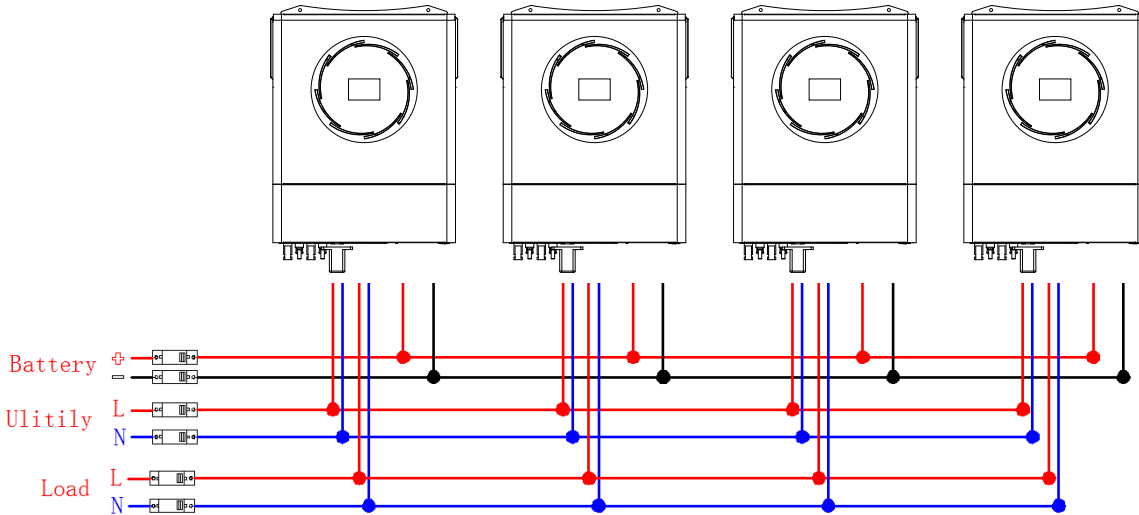

Communication Connection

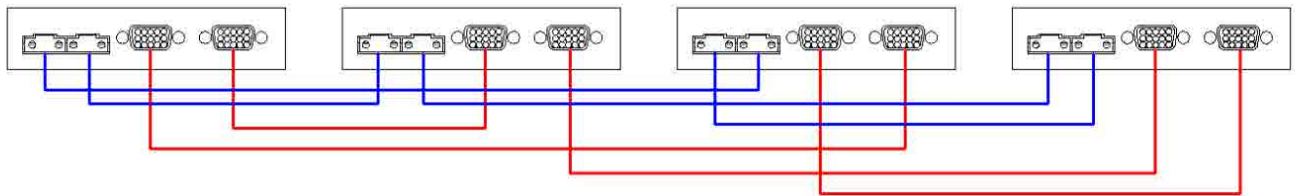

4. Five inverters in parallel :

Power Connection:

NOTE: The following picture is only a schematic diagram of the equipment .If the actual chassis does not conform to the schematic due to a structural upgrade, it is subject to prior notice.

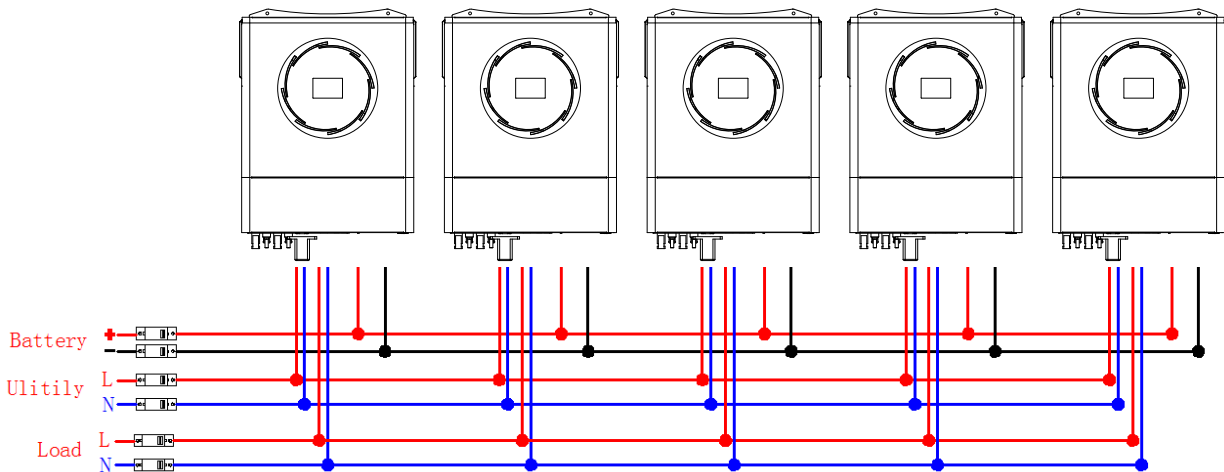

Communication Connection

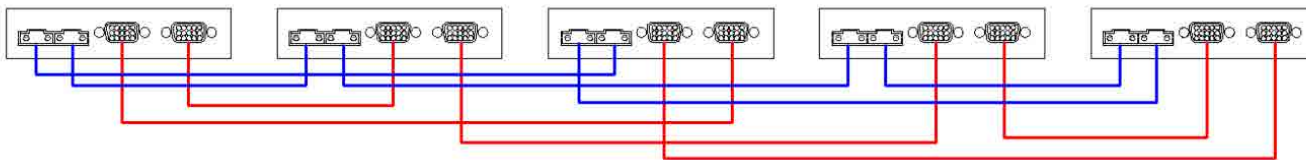

5.Six inverters in parallel :

Power Connection:

NOTE:The following picture is only a schematic diagram of the equipment .If the actual chassis does not conform to the schematic due to a structural upgrade, it is subject to prior notice.

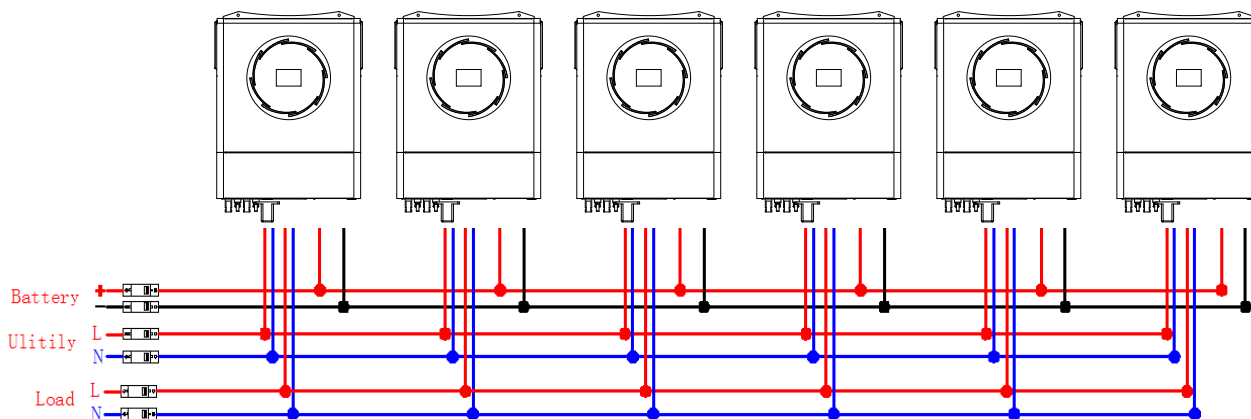

Communication Connection

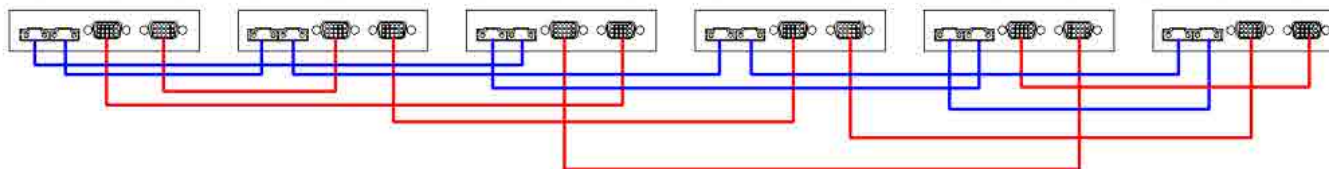

6.4 Matters Needing Attention In Three-phase Parallel Operation

1. Parallel operation in Three phase with up to 6 units.
2. **WARNING:** It's required to connect battery for parallel operation, it is forbidden to use parallel without batteries
3. **WARNING:** It is forbidden for inverter to share the same solar panel group.
4. **WARNING:** Make sure all cables are of the same length, Otherwise, there will be voltage difference between inverter and battery to cause parallel inverters not working.
5. Set the parameters of each inverter independently (working mode, three-phase parallel function and set A/B/C phase sequence).
WARNING: When working in parallel, the working mode of each inverter must be the same working mode, output frequency.
6. After setting the parameters, turn on each inverter in turn.
7. **WARNING:** When running in parallel, all inverters must share the battery pack.
8. **WARNING:** Do not connect the current sharing cable between the inverters which are in different phase. Otherwise ,it may damage inverters .

6.5 Three-phase Parallel Operation Cable Connection

1. One inverters in each phase:

Power Connection:

NOTE: The following picture is only a schematic diagram of the equipment .If the actual chassis does not conform to the schematic due to a structural upgrade, it is subject to prior notice.

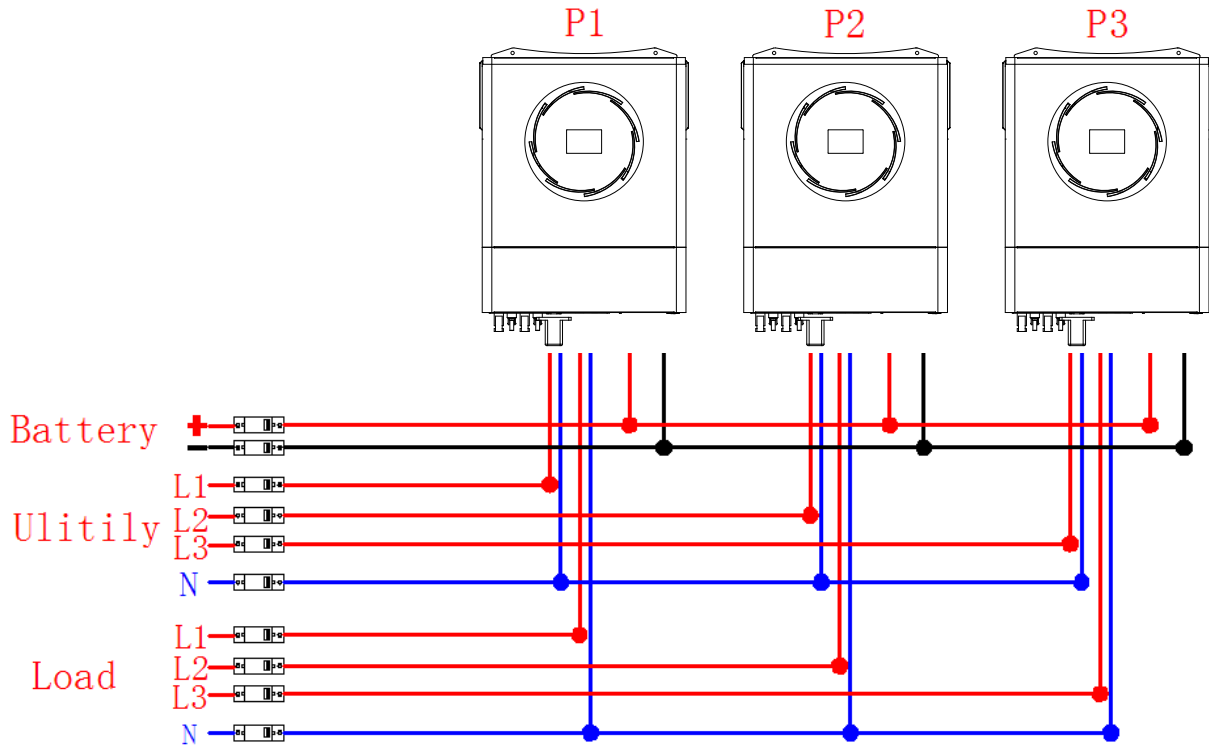

NOTE:P1: A-phase, P2: B-phase, P3: C-phase.

Communication Connection

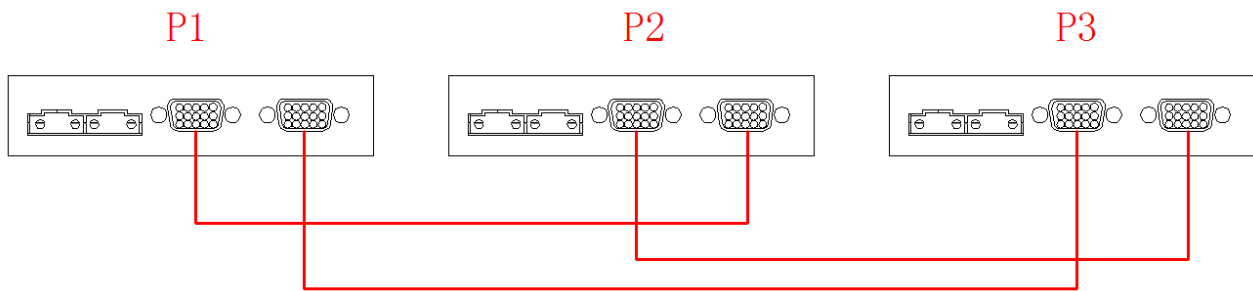

2. Two inverters in each phase:

Power Connection:

NOTE: The following picture is only a schematic diagram of the equipment .If the actual chassis does not conform to the schematic due to a structural upgrade, it is subject to prior notice.

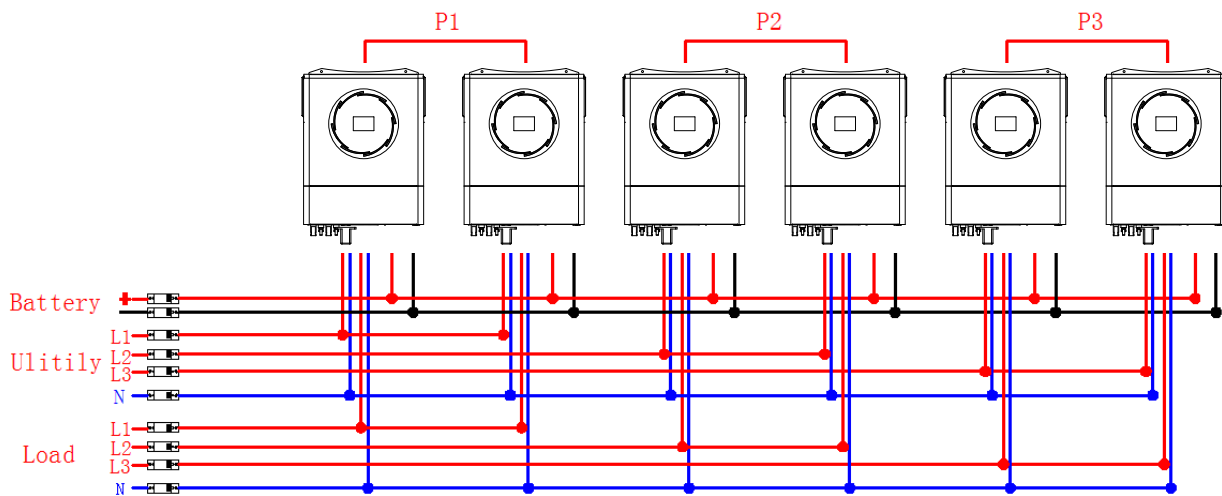

NOTE:P1: A-phase. P2: B-phase. P3: C-phase.

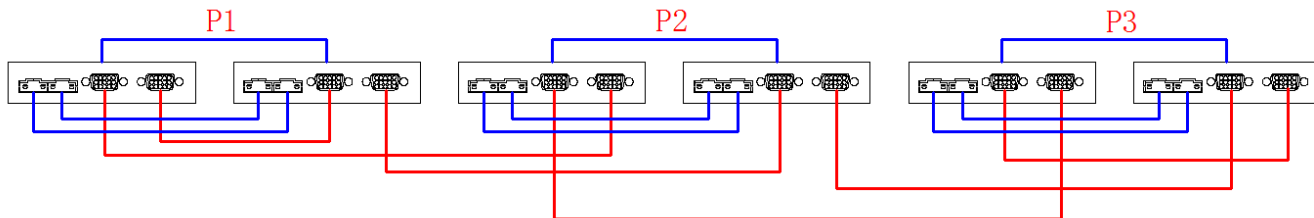

3. Four inverters in one phase and one inverter for the other two phases:

Power Connection:

NOTE: The following picture is only a schematic diagram of the equipment .If the actual chassis does not conform to the schematic due to a structural upgrade, it is subject to prior notice.

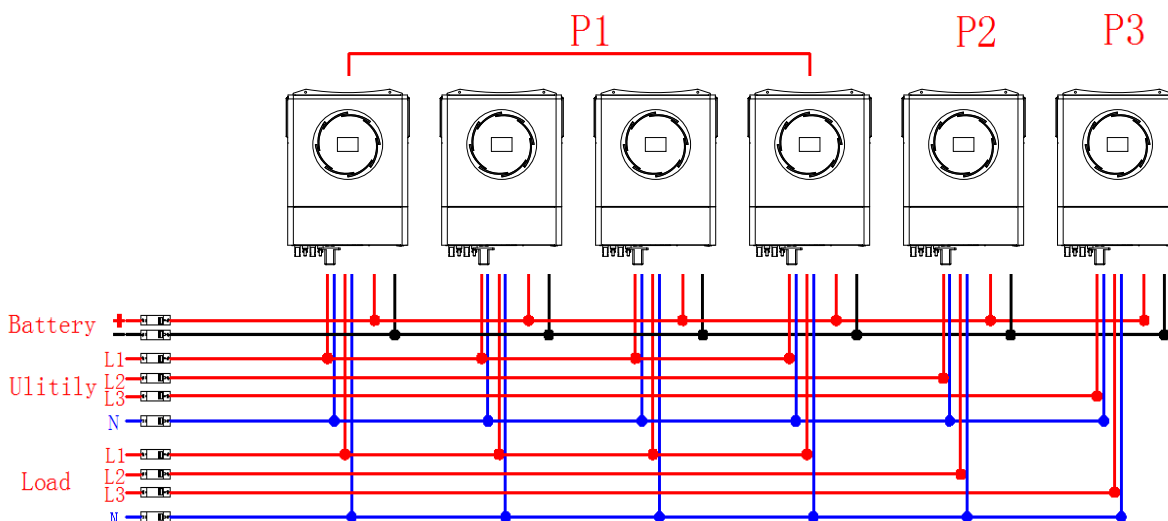

NOTE:P1: A-phase, P2: B-phase, P3: C-phase.

Communication Connection

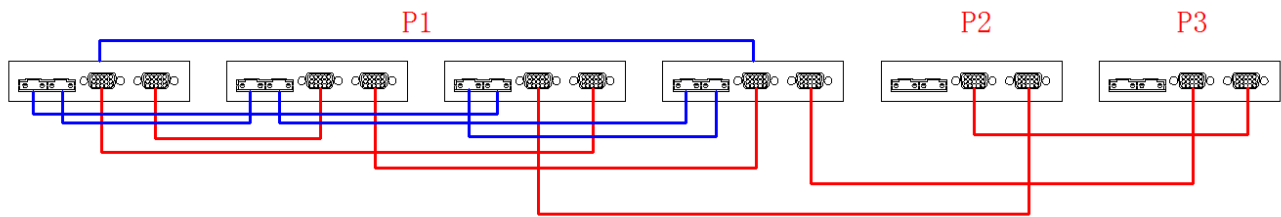

4. Three inverters in one phase, two inverters in second phase and one inverter for the third phase:
Power Connection:

NOTE: The following picture is only a schematic diagram of the equipment .If the actual chassis does not conform to the schematic due to a structural upgrade, it is subject to prior notice.

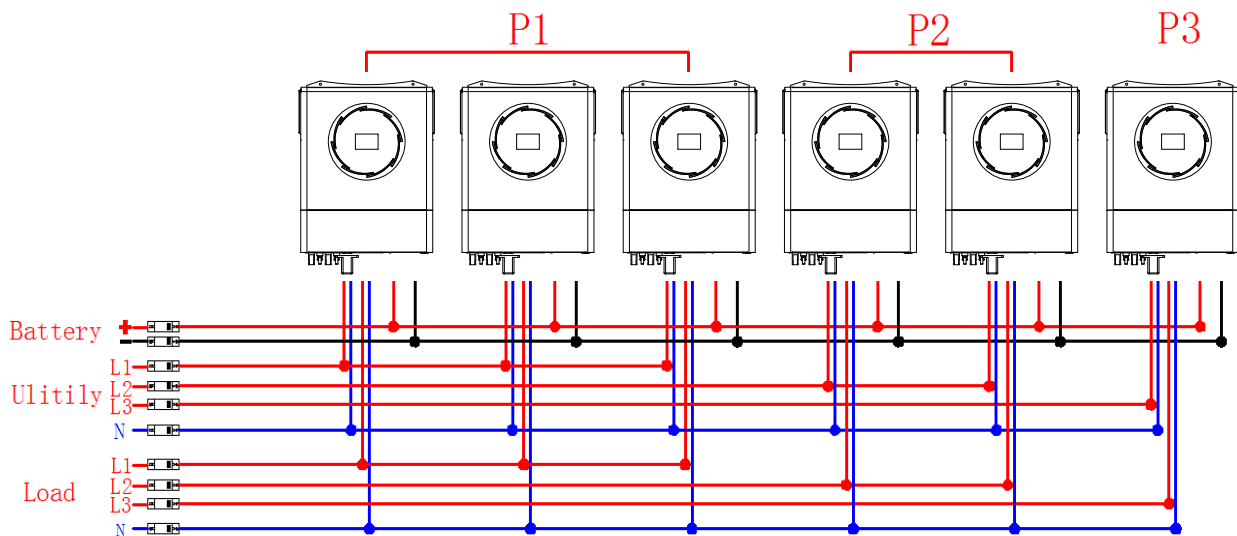

NOTE:P1: A-phase, P2: B-phase, P3: C-phase.

Communication Connection

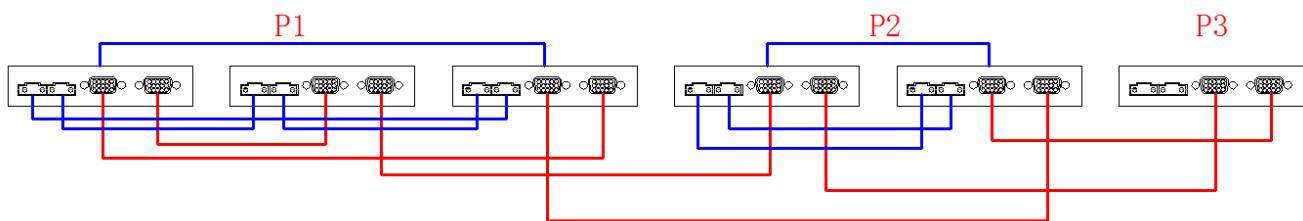

5. Three inverters in one phase and only one inverter for the remaining two phases:

Power Connection:

NOTE: The following picture is only a schematic diagram of the equipment .If the actual chassis does not conform to the schematic due to a structural upgrade, it is subject to prior notice.

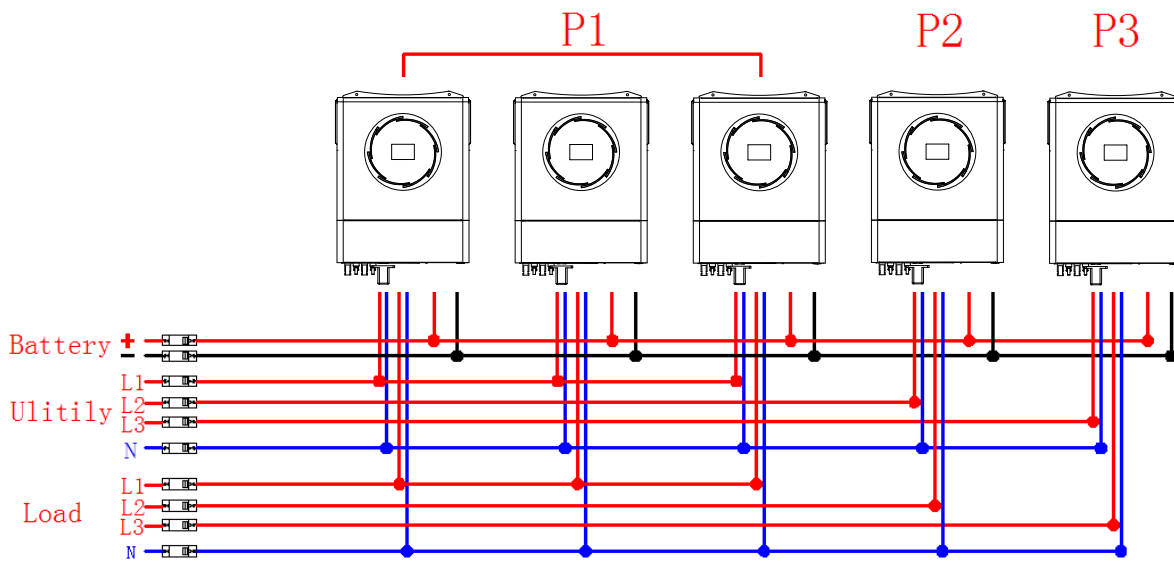

NOTE:P1: A-phase, P2: B-phase, P3: C-phase.

Communication Connection

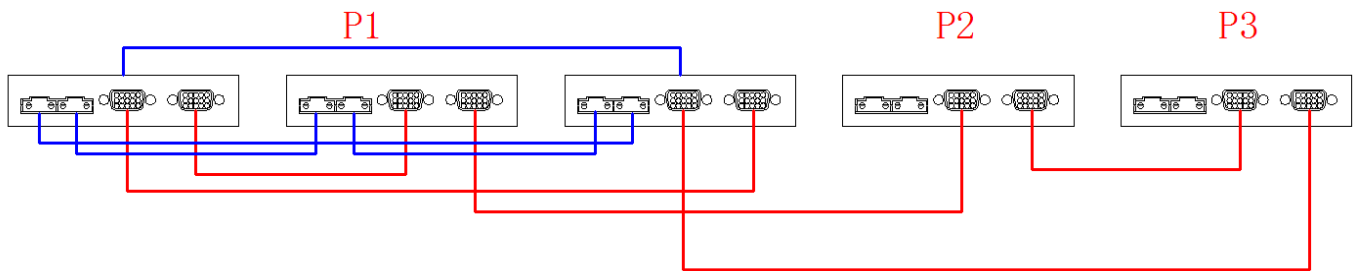

6.Two inverters in two phases and only one inverter for the remaining phase:

Power Connection:

NOTE: The following picture is only a schematic diagram of the equipment .If the actual chassis does not conform to the schematic due to a structural upgrade, it is subject to prior notice.

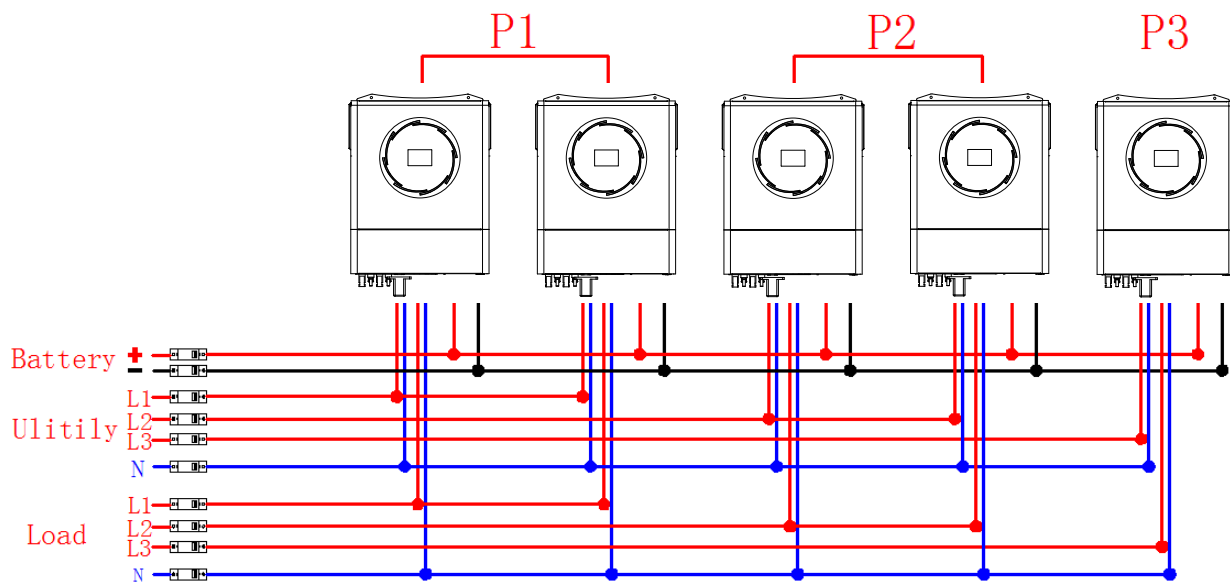

NOTE:P1: A-phase, P2: B-phase, P3: C-phase.

Communication Connection

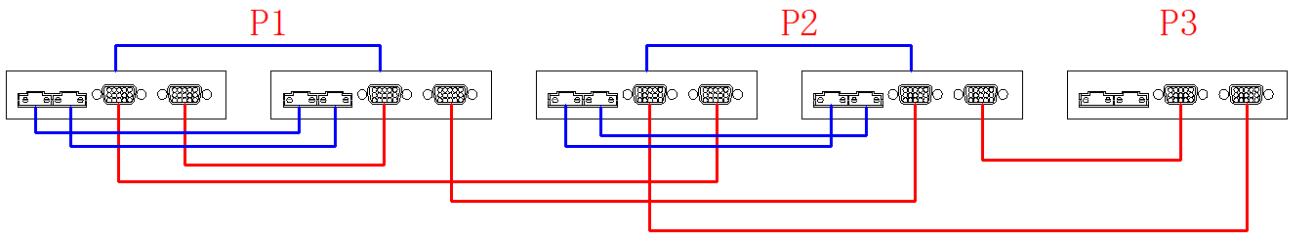

7. Two inverters in one phase and only one inverter for the remaining phases:

Power Connection:

NOTE: The following picture is only a schematic diagram of the equipment. If the actual chassis does not conform to the schematic due to a structural upgrade, it is subject to prior notice.

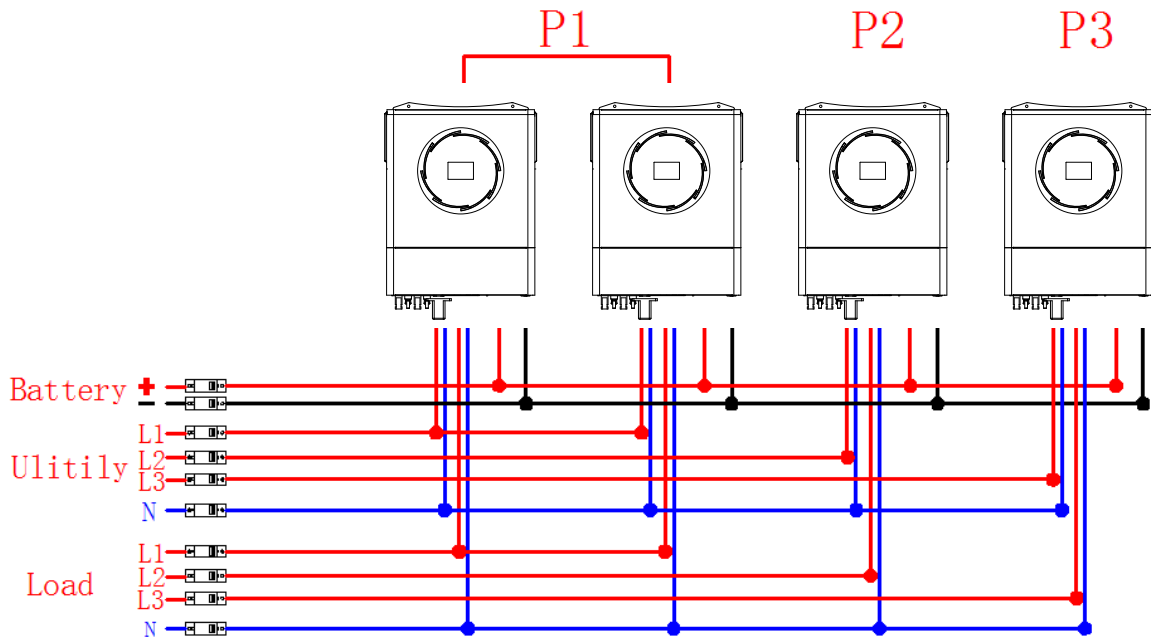

NOTE: P1: A-phase, P2: B-phase, P3: C-phase.

Communication Connection

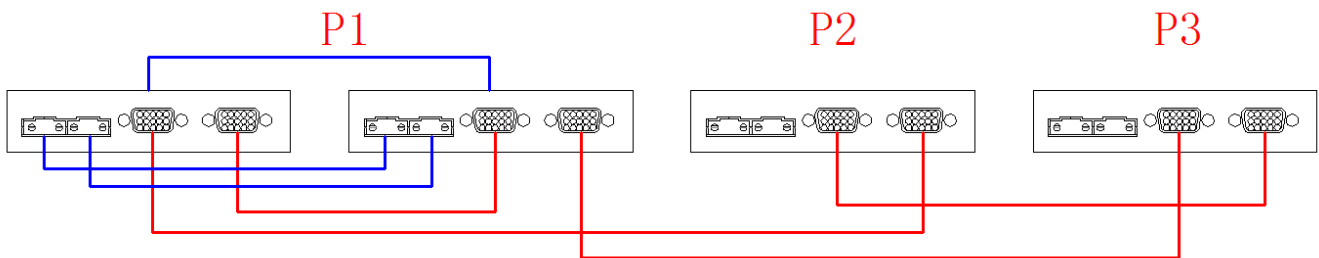

7. Faults Code

Fault Code	Fault Event
01	Fan is locked
02	Over temperature
03	Battery voltage is too high
04	Battery voltage is too low
05	Output short circuited.
06	Output voltage is too high.
07	Overload time out
08	Bus voltage is too high
09	Bus soft start failed
24	PV over temperature
52	Bus voltage is too low
53	Inverter soft start failed
55	Over DC voltage in AC output
57	Current sensor failed
58	Output voltage is too low

8. Warning Code

Warning Code	Warning Event
01	Fan is locked
02	Over temperature
03	Battery is over-charged
04	Low battery
07	Overload
10	Output power derating
08	Over current
15	PV energy is low
16	High AC input (>280VAC) during BUS soft start
21	PV low voltage
22	PV over voltage

9. Parallel Faults Code

Fault Code	Fault Event
60	Power feedback protection
71	Firmware version inconsistent
72	Current sharing fault
73	Output voltage different
80	CAN fault
81	Host loss
82	Synchronization loss
83	Battery voltage detected different
84	AC input voltage and frequency detected different
85	AC output current unbalance
86	AC output mode setting is different

10. Trouble Shooting

Problem	LCD/LED/Buzzer	Possible cause	What to do
Unit shuts down automatically during start up process	LCD/LED and buzzer will be active then complete off	The battery voltage is too low	1.Re-charge battery. 2. Replace battery
No response after power on	No indication	1.The battery voltage is too low. 2. Internal fuse tripped	1.Contact repair center for replacing the fuse. 2. Re-charge battery. 3. Replace battery.
Mains exist but the unit works in battery mode	Input voltage is displayed as '0' on the LCD and green LED is fashing	Input protector is triggered	Check if AC breaker is turned on and AC wiring is connected well.
	LED is fashing	Insufficient quality of AC power(grid or generator)	1. Check if AC wires are too thin and/or too long. 2. Check if generator (if applied) is working well or if input voltage range setting is correct.
When the unit is turned on, internal relay is switched on and off repeatedly	LCD display and LED fashing	Set "Solar First" as the priority of output source.	Change output source priority to utility first.
Buzzer beeps continuously and red LED is on	Fault code 01	Fan fault	Replace the fan
	Fault code 02	Internal temperature of inverter component is over 85°C	Check whether the environment around the equipment well ventilated
	Fault code 03	The battery voltage is too high	check if spec and quantity of batteries are meet requirements
		battery is over charged	Return to repair center
	Fault code 04	The battery voltage is too low	1.the battery is dead, please charge the battery immediately 2.check the battery for damage
	Fault code 05	Output short circuited	1.Check that the output cable is connected 2.return to the maintenance center
	Fault code 06/58	Output abnormal (Inverter voltage range 180-260VAC)	return to the maintenance center
	Fault code 07	Overload error , the inverter is overload 110% and overload time reaches the upper limit	reduce load

Buzzer beeps continuously and red LED is on	Fault code 08/09/12/53/57	Internal fault of inverter	return to the maintenance center
	Fault code 10	Over current or surge	Remove abnormal load or check PV input
	Fault code 11	The configuration of the solar panel is higher than the PV input voltage required by the inverter	remove the excess solar panels
	Fault code 13	Battery discharge over current	Please check whether the discharge current of Item 40 is lower than the discharge current of the inverter
	Fault code 52/55	Internal fault of inverter	return to the maintenance center
	Fault code 60	Power feedback protection	1.restart the inverter. 2.check if L/N cables are not Connected reversely in all inverters. 3.for parallel system in single phase ,make sure the sharing are connected in all inverters. For supporting three-phase system, make sure the sharing cables are connected in the inverters in the same phase. and disconnected in the inverters in different phase.
	Fault code 71	Firmware version inconsistent	1.update all inverter firmware to the same version 2.if the problem remains ,please contact your installer.
	Fault code 72	The output current of each inverter is different	1.check if sharing cables are connected well and restart the inverter. 2.if the problem remains ,please contact your installer.
Fault code 73	AC output voltage setting is different	Check whether the output voltage of each inverter are set the same	

	Fault code 80	CAN data loss	1. Check if communication cables are connected well and restart the inverter 2. If the problem remains, please contact your installer.
	Fault code 81	Host data loss(only for three-phase parallel)	
	Fault code 82	Synchronization data loss	
Buzzer beeps continuously and red LED is on	Fault code 83	The battery voltage of each inverter is not the same.	1. Make sure all inverters share same groups of batteries together. 2. Remove all loads and disconnect AC input and PV input. Then, check battery voltage of all inverters. If the values from all inverters are close, please check if all battery cables are the same length and same material type. Otherwise, please contact your installer to provide SOP to calibrate battery voltage of each inverter. 3. If the problem still remains, please contact your installer.
	Fault code 84	AC input voltage and frequency detected different	Check whether the input voltage and frequency of each inverter are set the same
	Fault code 85	AC output current unbalance	1. Restart the inverter 2. Remove some excessive loads and re-check load information from LCD of inverters. If the values are different, please check if AC input and output cables are in the same length and material type.
	Fault code 86	AC output mode setting is different.	check whether it is set to parallel mode 2. return to the maintenance center

11. Specifications

11.1 Line Mode Specifications

MODEL	8KW48Vdc
Input Voltage Waveform	Sinusoidal (utility or generator)
Nominal Input Voltage	230Vac
Low Loss Voltage	170Vac±7Vac (narrow range) 90Vac±7Vac (wide range)
Low Loss Return Voltage	180Vac±7Vac (narrow range) 100Vac±7Vac (narrow range)
High Loss Voltage	280Vac±7Vac
High Loss Return Voltage	270Vac±7Vac
Max AC Input Voltage	300Vac
Max AC Input Current	60A
Nominal Input Frequency	50Hz / 60Hz (Auto detection)
Low Loss Frequency	40±1Hz
Low Loss Return Frequency	42±1Hz
High Loss Frequency	65±1Hz
High Loss Return Frequency	63±1Hz
Output Short Circuit Protection	Line mode: AC input fuse Battery mode: Electronic Circuits
Efficiency (Line Mode)	>95% (Rated R load, battery full charged)
Transfer Time	10ms typical (narrow range)
Output power de-rating: When AC input voltage under 170V the output power will be de-rated.	<p>The graph shows Output Power on the vertical axis and Input voltage on the horizontal axis. A red line represents the power output capability. It starts at 0V, rises to a point labeled '50% Power' at 90V, then continues to rise to a point labeled 'Rated Power' at 170V. From 170V to 280V, the output power remains constant at the 'Rated Power' level. At 280V, the power drops to zero. Dashed lines connect the '50% Power' and 'Rated Power' labels to their respective points on the graph.</p>

11.2 Inverter Mode Specifications

MODEL	8KW48Vdc
Rated Output Power	8000W
Output Voltage Waveform	Pure Sine Wave
Output Voltage Regulation	230Vac±5%
Output Frequency	60Hz or 50Hz
Max. peak Efficiency	93%
Overload Protection	5s@≥150% load; 10s@110%~150% load
Surge Capacity	2* rated power for 5 seconds
Low DC Cut-off Voltage	42Vdc
Nominal DC Input Voltage	48Vdc
Cold Start Voltage	46.0Vdc
Low DC Warning Voltage @ load < 20%	44.0Vdc
@ 20% ≤ load < 50%	42.8Vdc
@ load ≥ 50%	40.4Vdc
Low DC Warning Return Voltage @ load < 20%	48.0Vdc
@ 20% ≤ load < 50%	44.8Vdc
@ load ≥ 50%	42.4Vdc
Low DC Cut-off Voltage @ load < 20%	44.0Vdc
@ 20% ≤ load < 50%	40.8Vdc
@ load ≥ 50%	38.4Vdc
High DC Cut-off Voltage	60Vdc
Communication	RS232 ,WIFI(option)

11.3 Charge Mode Specifications

Utility Charging Mode		
MODEL	8KW48Vdc	
Charging Current @ Nominal Input Voltage	120A	
Bulk Charging Voltage	Flooded Battery	58.4Vdc
	AGM / Gel Battery	56.4Vdc
Floating Charging Voltage	54.0Vdc	
Overcharge Protection	60.0Vdc	
Charging Algorithm	3-Step	
Charging Curve		
Solar Input		
MODEL	8KW48Vdc	
Max. PV Array Power	4000W*2	
Max. PV Array Open Circuit Voltage	450Vdc	
Nominal PV Voltage	360Vdc	
PV Array MPPT Voltage Range	120Vdc~450Vdc	
Max. Input Current	18A*2	
Power Limitation		

11.4 General Specifications

MODEL	8KW48Vdc
Safety Certification	CE
Operating Temperature Range	-10°C to 50°C
Storage temperature	-15°C~ 60°C
Humidity	5% to 95% Relative Humidity (Non-condensing)
Dimension (L*W*H), mm	551.55*422.20*152.00
Net Weight, kg	18.4

12. Installation Dimension Drawing

(unit:mm)

NOTE: The following picture is only a schematic diagram of the equipment .If the actual chassis does not conform to the schematic due to a structural upgrade, it is subject to prior notice.

