

TECHNICAL SPECIFICATIONS

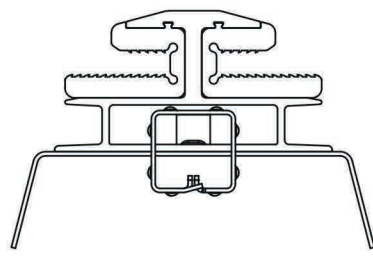

		ALUMINUM END CLAMP	ALUMINUM MID CLAMP
PRODUCT DETAILS	ARTICLE N°	244486	244488
	MATERIAL	Aluminum	
	DIMENSIONS IN MM	46 x 100 x 34	66 x 100 x 34
	WEIGHT IN G	76,5	111,2
PERFORMANCES	MECHANICAL RESISTANCE: +/-2400 Pa. compliant with IEC 61215-10,16:2005		
ENVIRONMENT	RAIL SPECIFICATIONS	Examples of technical drawings 1 and 2	
	MODULE SPECIFICATIONS	Frameless Dual Glass module 6 mm -0,2/+0,5	

EXAMPLES OF ASSEMBLY SCHEMATICS

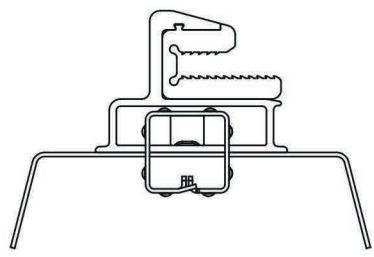
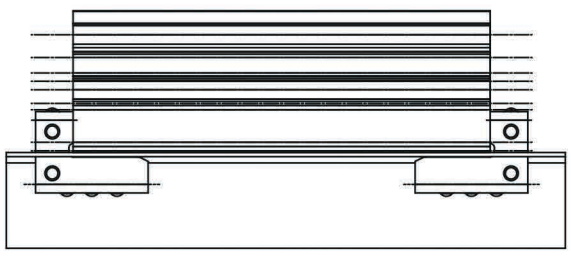

See product data sheet of PowAR Cinch™

1 Punch for rail interface

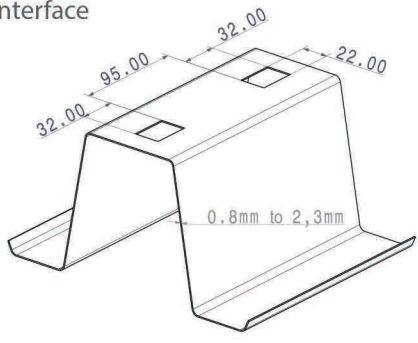

2 Possible rail profiles

